

Rev	Description	Date	Name

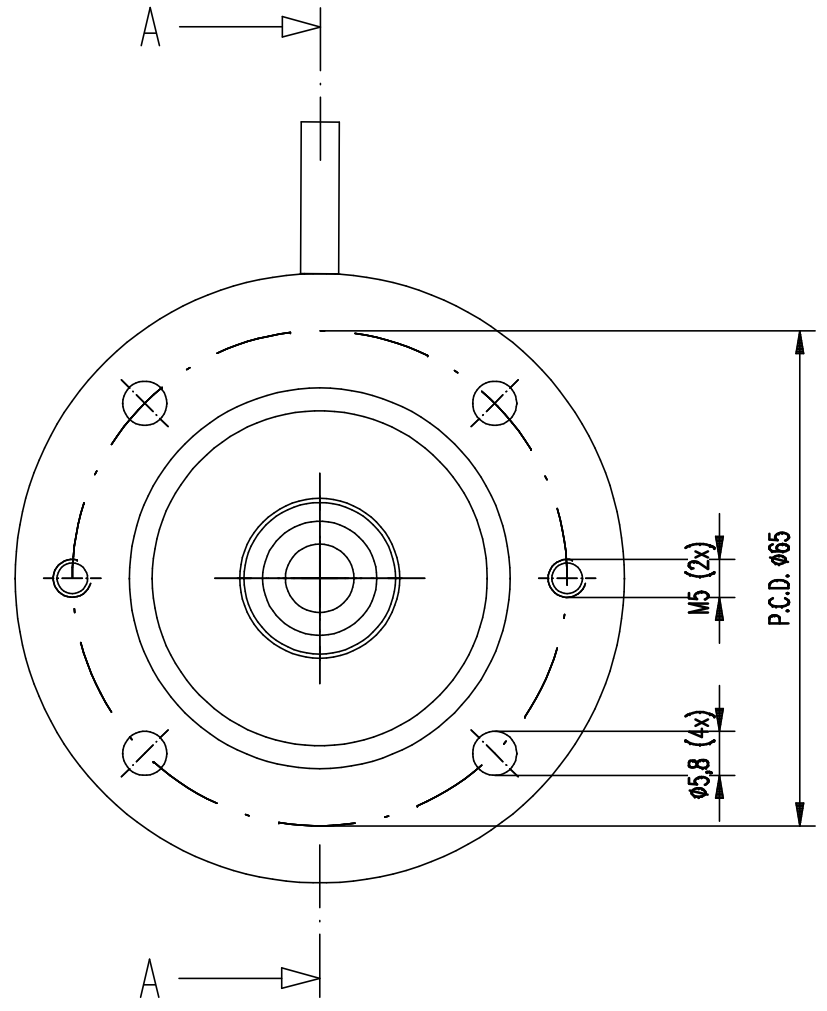
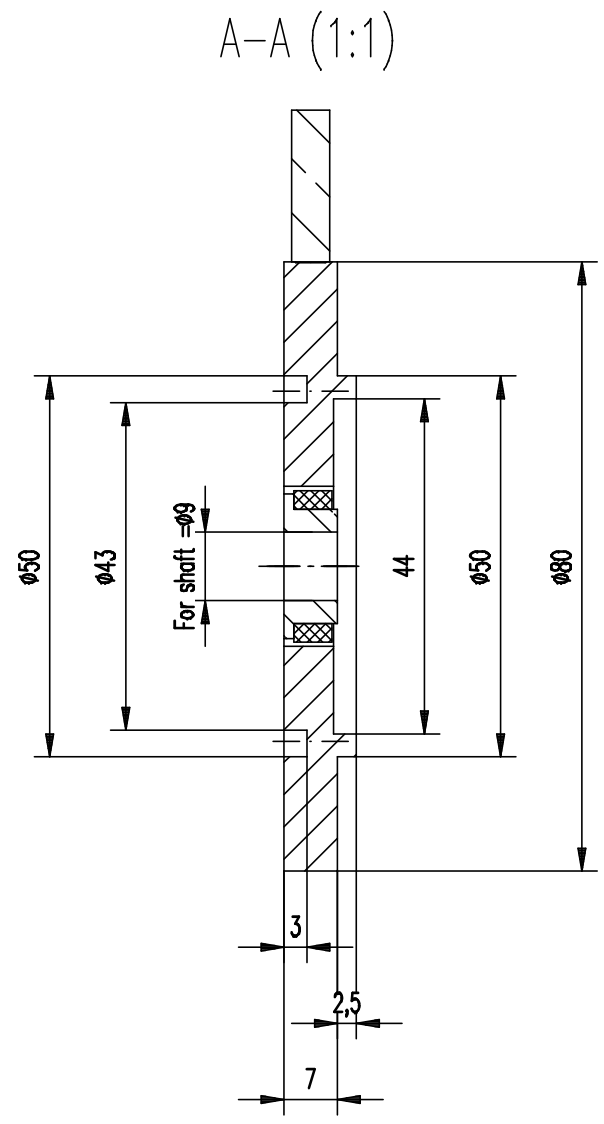
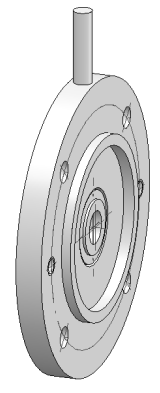

		MODEL. NO.	MATERIAL	WN.	<p>BEGE Aandrijftechniek B.V. BEGE Power Transmission Anton Philipsweg 30 2171 KX Sassenheim Nederland T +31 252-220220 F +31 252-218484 bege@bege.nl www.bege.nl</p>	
REV	WEIGHT	DESCRIPTION		DRAWN		CHECKED
SCALE	DIMENSIONS	MIG Nova+ Flange $\varnothing 80/7$		13.07.2020		13.07.2020
1:1	mm	Shaft $\varnothing 9$		DRW. NO.		DN-0009701
FORMAT	SH.NO.	ART. NO.	ERP ART. NO.	REF. DRW.	General tolerance	Surface
A3		AN-0006341			DIN-ISO 2768	1-m / 2-K

Copyright BEGE, whose property this document remains. No part may be disclosed, duplicated or in any other way made use of except with the written approval of BEGE. All rights reserved.