

# bj·gear



## Stainless steel motors

High quality and washdown tolerant

Customisation is our standard

## Stainless steel motors

BJ-Gear A/S produces stainless steel gearboxes, actuators, brakes and machine feet. To complement our range of stainless steel products, we distribute high quality stainless steel motors, that comply to the requirements listed in the European standard EN 1672-2.

The stainless steel motors are developed specifically for the food industry and other industries, that make heavy demands on material resistance and a design that is easy to clean. The motors have "clean lines" and a round smooth terminal box, which is machined and welded directly onto the frame of the motor.

Furthermore, motors below 1.10 kW has no cooling fins and due to their design alle motors have cleaner lines and fewer areas for entrapment of dirt or waste product, as well as no paint to chip or flake off and no surface that will rust. Waste products can be washed away easily leaving no residue.

### Clean-in-place and IP66 sealing

When food, beverage or pharmaceutical production plants are washed down, the motors are exposed to high pressure jets of sometimes high temperature water or aggressive cleaners. Depending on the severity of the down washing, many consequences can be encountered if standard alloy or cast iron material is used, including engine shutdown at start up due to ingress of water, corrosion of external or internal parts, as well as a risk of paint flaking or contamination of the final product itself.

Our stainless steel motors are manufactured in Europe and exceed IP66 during external testing. When TENV motors are mounted on a gearbox with correct cable and cable gland they meet the requirements for IP69K. The range is a proven design for Clean-In-Place (CIP) areas and washdown situations. A Viton double lip seal and a second GAMMA seal fitted on the shaft are examples of the attention to detail for protection against potential ingress during washdown

### Corrosion resistant

All external metal components including motor shafts are manufactured in EN 1.4301/AISI 304 stainless steel.



This gives excellent corrosion resistance. With a highly chemically resistant surface, they far out live standard painted motors in hygiene applications.



## TEFC and TENV

The motors can be supplied as Totally Enclosed Fan Cooled motors (TEFC) or as Totally Enclosed Non Ventilated motors (TENV).

TEFC-motors rely on air being pulled from the non-drive end of the motor through a fan; this is then blown over the motor body to help dissipate the generated heat.

TENV-motors work on the basis of more active material and optimised efficiencies, reducing the heat generated through losses thus negating the need for a fan.

### Etched nameplates

The nameplates and fixings on standard motors are prime areas for waste and dirt entrapment. They corrode, get damaged and even detach.



The stainless motor range has the technical data etched directly onto the motor body, thus eliminating these hygiene and safety risks.

### UL logo on motor



## Regulations

The European standard EN 1672-2, that defines hygiene requirements for food production machinery, specifies three zones for the industry:

- 1 Food zone
- 2 Splash zone
- 3 Non-food zone

The non-food zone covers components which do not come in contact with foodstuffs. It is nonetheless still mandatory to use corrosion-resistant materials in the non-food zone.

# Data

3000 rpm (2 pole)							Direct on line starting				
Type	Rated output	Rated speed	Efficiency	Voltage connection	Rated current at voltage	100% Full load torque	Starting current ratio	Break-away torque	Pull out torque	B14(2)	B5(2)
IEC Frame	kW	min-1	% FL	▲/Y		Nm	IA/IN	MA/MN	MK/MN	kg	kg
TENV 63A-2	0.18	2800	IE4-75.0	230/400	0.78/0.45	0.62	4.7	3.3	3.1	8.0	9.0
TENV 63B-2	0.25	2830	IE4-76.8	230/400	1.00/0.58	0.84	6.4	4.4	4.2	9.0	10.0
TENV 71A-2	0.37	2830	IE4-80.4	230/400	1.39/0.80	1.26	6.4	3.9	3.8	11.6	12.8
TENV 71B-2	0.55	2880	IE4-82.0	230/400	1.92/1.11	1.85	7.8	4.8	4.6	14.5	15.7
TENV 80A-2	0.75	2900	IE4-84.6	230/400	2.51/1.45	2.48	8.4	3.9	3.6	19.0	21.5
TEFC 80B-2	1.10	2885	IE4-85.2	230/400	3.60/2.08	3.64	7.0	2.5	2.9	22.0	23.5
TEFC 90S-2	1.50	2875	IE3-84.2	230/400	5.28/3.05	4.98	8.4	4.8	4.4	23.3	25.0
TEFC 90L-2	2.20	2840	IE3-85.9	230/400	7.36/4.25	7.41	7.1	3.7	3.5	26.0	27.7
TEFC 100L-2	3.00	2910	IE3-87.1	230/400	9.53/5.50	9.85	8.0	2.6	3.5	41.0	43.3
TEFC 112M-2	4.00	2930	IE3-88.1	400/690	7.27/4.20	13.04	9.0	2.8	4.2	49.0	52.0
TEFC 132M-2	7.50	2940	IE3-90.5	400/690	13.15/7.59	24.43	5.2	2.4	3.9	78.0	84.0

1500 rpm (4 pole)							Direct on line starting				
Type	Rated output	Rated speed	Efficiency	Voltage connection	Rated current at voltage	100% Full load torque	Starting current ratio	Break-away torque	Pull out torque	B14(2)	B5(2)
IEC Frame	kW	min-1	% FL	▲/Y		Nm	IA/IN	MA/MN	MK/MN	kg	kg
TENV 63B-4	0.18	1385	IE3-71	230/400	0.95/0.55	1.25	3.8	2.6	2.5	9.0	10.0
TENV 71A-4	0.25	1440	IE4-81	230/400	1.07/0.62	1.67	5.1	2.3	2.8	12	13.2
TENV 71B-4	0.37	1440	IE3-80	230/400	1.80/1.04	2.48	4.5	2.4	2.9	12.8	14.0
TENV 80A-4	0.55	1440	IE3-82	230/400	2.35/1.35	3.68	5.7	3.2	3.1	17.0	18.5
TENV 80B-4	0.75	1450	IE4-85.7	230/400	3.08/1.78	4.90	7.0	3.1	3.8	24.0	25.5
TENV 90S-4	1.10	1460	IE3-85.8	230/400	4.33/2.50	7.14	9.4	3.4	4.5	30.0	31.7
TEFC 90S-4	1.10	1445	IE3-84.5	230/400	4.07/2.35	7.29	5.8	2.2	2.7	21.5	23.2
TEFC 90L-4	1.50	1450	IE3-85.3	230/400	5.54/3.20	9.88	6.6	2.5	2.9	23.5	25.2
TEFC 100LA-4	2.20	1440	IE3-86.7	230/400	7.62/4.40	14.59	6.9	2.6	3.2	45.0	47.3
TEFC 100LB-4	3.00	1455	IE3-87.7	230/400	10.57/6.10	19.70	7.8	3.4	3.8	50.0	52.3
TEFC 112M-4	4.00	1465	IE3-88.6	400/690	8.35/4.82	26.02	5.8	2.2	3.1	55.0	58.0
TEFC 132M-4(3)	7.50	1460	IE3-90.4	400/690	14.70/8.49	49.14	9.2	2.5	4.2	86.0	92.0

1000 rpm (6 pole)							Direct on line starting				
Type	Rated output	Rated speed	Efficiency	Voltage connection	Rated current at voltage	100% Full load torque	Starting current ratio	Break-away torque	Pull out torque	B14(2)	B5(2)
IEC Frame	kW	min-1	% FL	▲/Y		Nm	IA/IN	MA/MN	MK/MN	kg	kg
TENV 71A-6	0.18	925	IE3-70.0	230/400	0.92/0.53	1.86	3.5	2.2	2.3	11.9	12.2
TENV 71B-6	0.25	930	IE4-76.9	230/400	1.32/0.77	2.56	3.7	2.3	2.4	14.2	15.4
TENV 80A-6	0.37	930	IE3-77.8	230/400	1.70/0.98	3.73	*	*	*	20.5	22
TENV 80B-6	0.55	930	IE3-78.0	230/400	2.60/1.50	5.62	*	*	*	23.0	24.5
TEFC 90S-6	0.75	960	IE3-81.7	230/400	3.19/1.84	7.47	*	*	*	25.0	26.7
TEFC 90L-6	1.10	950	IE3-82.7	230/400	4.56/2.63	11.06	*	*	*	30.0	31.7

Full data sheet is available upon request, including 60Hz data. (All motors are able to run at 60Hz).

2) Motor weights are unboxed, please add for packaging.

3) Acc. to EU commission regulation EC640/2009 from Jan 01 2015 all motors installed in the european market are >7.5kW IE2 used with variable speed drive.

\* Test results awaiting

# Dimensions

Frame size 63 to 90 - B14 face mounted - TENV																				
Frame type	Poles	Face	D	E/LE	F	G	M	N	P	S	T	U	ØW	AC	AD	DB	WC	2 pole L	4 pole L	6 pole L
			mm	mm	mm	mm	mm	mm	mm		mm		mm	mm	mm		mm	mm	mm	mm
TENV 63A-2	2	FT75	11	23	4	8.5	75	60	90	M5	2.5	M20	76	114	111	M4	79	211	x	x
TENV 63B*	2, 4	FT75	11	23	4	8.5	75	60	90	M5	2.5	M20	76	114	111	M4	79	236	236	x
TENV 71A*	2, 4, 6	FT85	14	30	5	11	85	70	105	M6	2.5	M20	76	134	124	M5	88	243	243	253
TENV 71B*	2, 4, 6	FT85	14	30	5	11	85	70	105	M6	2.5	M20	76	134	124	M5	88	273	254	273
TENV 80A*	2, 4, 6	FT100	19	40	6	15.5	100	80	120	M6	3	M25	89	144	135	M6	99	337	307	307
TENV 80B*	2, 4, 6	FT100	19	40	6	15.5	100	80	120	M6	3	M25	89	144	135	M6	99	337	347	347
TENV 90S*	4	FT115	19	50	6	16	115	95	140	M8	3	M25	89	176	147	M8	105	x	378	x

Frame size 80 to 132 - B14 Face mounted - TEFC																				
Frame type	Poles	Face	D	E/LE	F	G	M	N	P	S	T	U	ØW	AC	AD	DB	WC	2 pole L	4 pole L	6 pole L
			mm	mm	mm	mm	mm	mm	mm		mm		mm	mm	mm		mm	mm	mm	mm
TEFC 80B-2	2	FT100	19	40	6	16	100	80	120	M6	3	M25	89	156	135	M8	99	363	x	x
TEFC 90S*	2, 4, 6	FT115	24	50	8	20	115	95	140	M8	3	M25	89	176	147	M8	105	372	353	392
TEFC 90L*	2, 4, 6	FT115	24	50	8	20	115	95	140	M8	3	M25	89	176	145	M8	105	396	372	422
TEFC 100LA*	4	FT130	28	60	8	24	130	110	160	M8	3.5	M25	114	203	165	M10	123	x	465	x
TEFC 100LB*	4	FT130	28	60	8	24	130	110	160	M8	3.5	M25	114	203	165	M10	123	x	512	x
TEFC 112*	2, 4	FT130	28	60	8	24	130	110	160	M8	3.5	M25	114	218	176	M10	133	493	493	x
TEFC 132*	2	FT165	38	80	10	33	165	130	200	M10	3.5	M25	114	258	197	M12	132	493	x	x

\*denotes poles

Frame size 63 to 80 - B5 Flange mounted - TENV																				
Frame type	Flange	Poles	D	E/LE	F	G	M	N	P	S	T	U	ØW	AC	AD	DB	WC	2 pole L	4 pole L	6 pole L
			mm	mm	mm	mm	mm	mm	mm		mm		mm	mm	mm		mm	mm	mm	mm
TENV 63 1 2	FF115	2	11	23	4	8.5	115	95	140	Ø10	2.5	M20	76	114	119	M4	79	211	x	x
TENV 63 2*	FF115	2, 4	11	23	4	8.5	115	95	140	Ø10	2.5	M20	76	114	119	M4	79	236	236	x
TENV 71 1*	FF130	2, 4, 6	14	30	5	11	130	110	160	Ø10	3.5	M20	76	134	129	M5	88	243	243	253
TENV 71 2*	FF130	2, 4, 6	14	30	5	11	130	110	160	Ø10	3.5	M20	76	134	129	M5	88	273	254	273
TENV 80 1*	FF165	2, 4, 6	19	40	6	15.5	165	130	200	Ø12	3.5	M25	89	144	135	M6	99	337	307	307
TENV 80 2*	FF165	2, 4, 6	19	40	6	15.5	165	130	200	Ø12	3.5	M25	89	144	135	M6	99	337	347	347

Frame size 80 to 132 - B5 Flange mounted - TEFC																				
Frame type	Flange	Poles	D	E/LE	F	G	M	N	P	S	T	U	ØW	AC	AD	DB	WC	2 pole L	4 pole L	6 pole L
			mm	mm	mm	mm	mm	mm	mm		mm		mm	mm	mm		mm	mm	mm	mm
TEFC 80 2 2	FF165	2	19	40	6	16	165	130	200	Ø12	3.5	M25	89	156	135	M6	99	363	x	x
TEFC 90 S*	FF165	2, 4, 6	24	50	8	20	165	130	200	Ø12	3.5	M25	89	176	147	M8	105	372	353	392
TEFC 90 L*	FF165	2, 4, 6	24	50	8	20	165	130	200	Ø12	3.5	M25	89	176	147	M8	105	396	372	422
TEFC 100 L1*	FF215	2, 4, 6	28	60	8	24	215	180	250	Ø15	4	M25	114	203	165	M10	123	450	465	487
TEFC 100 L2*	FF215	4	28	60	8	24	215	180	250	Ø15	4	M25	114	203	165	M10	123	x	512	x
TEFC 112*	FF215	2, 4, 6	28	60	8	24	215	180	250	Ø15	4	M25	114	218	176	M10	133	493	493	x
TEFC 132*	FF265	2, 4, 6	38	80	10	33	265	230	300	Ø15	4	M25	114	258	197	M12	132	x	577	x

B3 foot mounted TENV and TEFC are available upon request

# Drawings

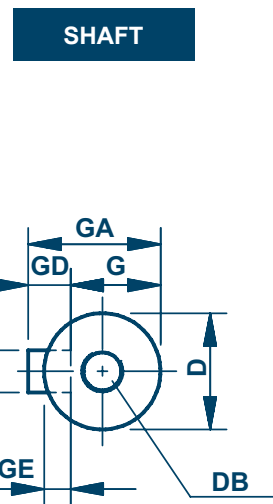
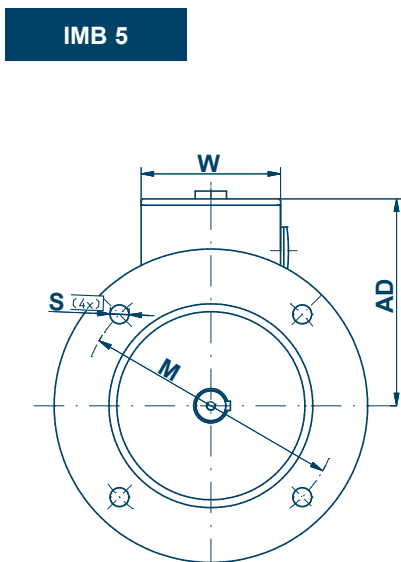
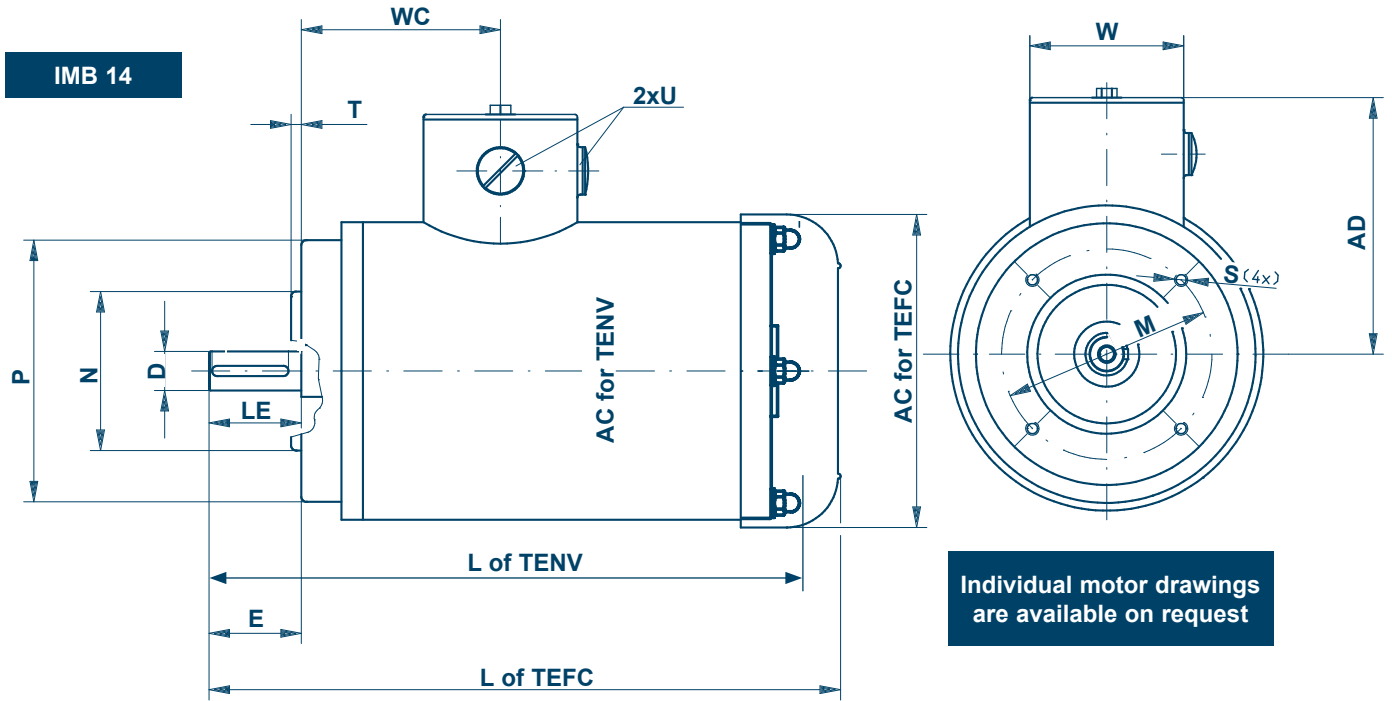



# Features and optional choices

## Bearings

The bearings have special synthetic high-temperature lubricating grease with a wide operating range from -40°C to 180°C, and an excellent drop point, DIN ISO 2176 ≥ 250°C. They have outstanding ageing and oxidation stability and C3 clearance. The motors are fixed at the drive end to reduce axial shaft movement, which makes the motors suitable for mixers and close-coupled pumps.

Frame size	Drive end/ Non-drive end
63	6202
71	6203
80	6204
90	6205
100	6306
112	6306
132	6308

## Tropicalised internal components

The stainless steel motors have corrosion-resistant rotors and advanced winding varnishing techniques, that dramatically increase the motor's reliability and expected lifetime. Windings can be spot-wound for special voltage and frequencies outside of European standards, thermal insulation to Class 180 (H), cert155.1.0 - E313095. Furthermore, Atex, zone 22 is available upon request.

## Phase barriers and thermistors

The stainless steel motor range is suitable for inverter drive use and has phase barriers and PTC 155°C thermistors fitted as standard. On request PTO (Klixon style) bi-metallic thermostats can be fitted as an alternative to protect against over-temperature. Also, we offer water cooled stainless steel motors for extreme high ambient environments and where more compact and high powers are necessary - more cooling equals more power.



## Customisation

The standard IEC flange configurations are commonly required for the majority of pump and fan applications. However, we are also able to produce special drive end flange and shaft solutions for customised machinery.

## Optional enhanced sealings for extreme applications

Enhanced sealing techniques can extend the motor's lifetime drastically in extreme applications and mounting conditions, predominantly vertical shaft up. Magnetic sealing systems with precise labyrinth clearances are available for such arduous applications. These compact, precision lapped, mechanical face seals give bi-directional protection where 100% positive seal protection is required with or without shaft rotation. This is very important to prevent pooling issues in shaft up applications when stationary or cooling back. They create zero shaft wear, prevent lubrication loss, eliminate contamination (solids, liquids and steam), have self-aligning faces and increase the equipment MTBF (Mean Time Between Failure).

Encapsulated compound completely moulds and protects the connections inside the terminal box as well as the flying leads.

## No need to brush or bag, just wash it away

STAINLESS



Before cleaning



During cleaning



After cleaning

STANDARD



Before cleaning



During cleaning



After cleaning

## Optional features

- Alternative terminal box positions for foot mounted motors.
- Pharmaceutical grade polishing that exceeds 0.5 microns.
- Heaters used to reduce condensation and keep moisture out. They also help keep windings and bearings within normal operating temperature in low ambient conditions.
- Application specific drain plugs can be fitted when needed as a proven way of removing condensation from inside the motor.



## Complete solutions

To complete your stainless steel transmission solution, BJ-Gear A/S supply numerous accessories of stainless steel. All our stainless steel products are developed specifically for the food industry or other industries, that are continuously making heavier demands on the material resistance and a design, that is easy to clean.

### Gearboxes and actuators

The gearboxes and actuators are designed with a smooth, stainless steel gear housing. They are lubricated for life and can be supplied with a lubricant approved for the food industry. The oil sealings are made of nitrile rubber.

### Brakes

Motor frame size	Brake size	M <sub>bN</sub>	P 20° C	Cable length standard
		[Nm]	[Watt]	[Meter]
63,71	8	5	22	1
80	10	10	28	1
90	13	20	34	1

\*Braking torque after completion of running-in. The brake is designed to be mounted between a flanged motor and a gearbox, hence the output shaft cannot be subjected to additional axial or radial loads.



### Stainless Worm Gearbox



### Stainless Helical Bevel gearbox



### Stainless worm gear screw jack



### Stainless Actuator



## Safety standards

Our stainless motors comply with the requirements of the International Standard IEC 60034 for rotating electrical machines as well as the following European Directives: Low Voltage Directive (LV) 2006/95/EC, Electromagnetic Compatibility Directive (EMC) 2004/108/EC and RoHS Directive 2011/65/EC on the restriction of hazardous substances in electrical and electronic equipment.



All stainless motors comply with the requirements of the Machines Directive (MD) 2006/42/EC. In accordance with this Directive, induction motors are components intended solely for integration into other machines. Commissioning is forbidden until conformity of the end-product with this Directive is proven.

When operating the motor, the observance of the Regulation EN 60204-1 and safety instructions indicated in our Operating Instructions must be complied with.

Motors can be supplied with insulation approved by Underwriters Laboratories Inc.(UL)



Quality conformities, standards and regulations  
Manufactured to a Quality Management System ISO9001:2008.

# bj·gear

Customisation is our standard



## BJ-Gear A/S

Niels Bohrs Vej 47  
DK-8660 Skanderborg, Denmark  
VAT No. DK 10166470

Phone +45 87 40 80 80  
Email [bj@bj-gear.com](mailto:bj@bj-gear.com)  
Website [www.bj-gear.com](http://www.bj-gear.com)

Copyright © 2022 BJ-Gear A/S. All product rights reserved. All data, illustrations, photos, drawings and statements are for general information only and subject to change without notice and should not be considered as a warranty or legal obligation of any kind.