

Operating and Installation Instructions Version 04.2013

for the electromagnetically released
Spring-Applied Brakes (Standard Design)

FDB 08 ... FDB 40

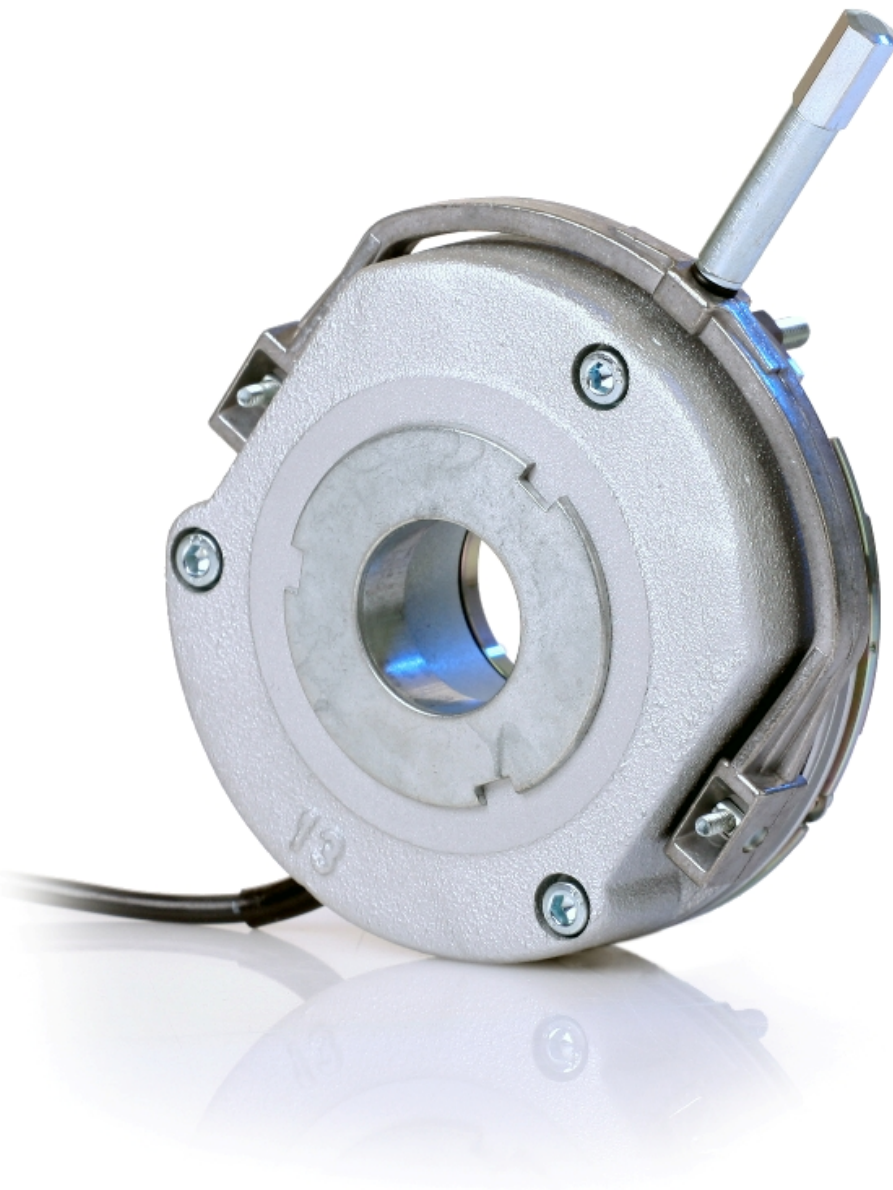

Table of Contents

1. Information on Operating and Assembly Instructions

- 1.1 Validity
- 1.2 Purpose and Use
- 1.3 Terms and Identification of Notices

2. Conditions for Assembly and Operation

- 2.1 Persons
 - 2.1.1 Operator
 - 2.1.2 Personnel
- 2.2 Product
 - 2.2.1 Area of Application
 - 2.2.2 Environment of Application
 - 2.2.3 State of Application
 - 2.2.4 General Conditions of Operation
- 2.3 Proper Use
- 2.4 Legal Aspects
 - 2.4.1 Liability
 - 2.4.2 Warranty
 - 2.4.3 Directives and Standards
- 2.5 Delivery scope and state

3. Product Description

- 3.1 Labelling
 - 3.1.1 Lettering
 - 3.1.2 Type Designation Code
- 3.2 Technical Information
 - 3.2.1 Operation of the Brake
 - 3.2.2 Technical Data

4. Assembly

- 4.1 Mechanical Installation
 - 4.1.1 Prerequisites and Preparation
 - 4.1.2 Counter-Friction Surface
 - 4.1.3 Hub and Rotor
 - 4.1.4 Brake
- 4.2 Electrical Installation

- 4.3 Conversions and Supplements
 - 4.3.1 Change of Braking Torque
 - 4.3.2 Subsequent Assembly of Manual Release

5. Operation

- 5.1 Brake in Operation
 - 5.1.1 Commissioning
 - 5.1.2 Running Operation
 - 5.1.3 Maintenance
- 5.2 Brake out of Operation (Malfunctions)

6. Disassembly / Exchange

- 6.1 Removing the Brake
- 6.2 Exchange of Components
- 6.3 Exchange of Brake / Disposal
- 6.4 Spare parts

1. Information on Operating and Assembly Instructions

1.1 Validity

These operating and assembly instruction (in accordance with their title) are generally valid only for the **standard design of the electromagnetically released spring-applied brakes FDB 08 to FDB 40** of M/s. PRECIMA Magnettechnik GmbH. Moreover, they are a necessary element of every brake delivery and generally only valid for such simultaneously delivered brakes. The operating and assembly instruction will even continue to be valid for such brakes, if a later version of the instructions exists, unless M/s. PRECIMA expressly declares to the customer that the later version replaces the older one.

In individual cases, the above mentioned principles may be deviated from (e.g. in case of special designs or repeated deliveries). In any case, an indicative or supplementing information of M/s. PRECIMA will be required.

1.2 Purpose and Use

These operating and assembly instructions are to contribute to a safe and proper assembly and operation of the spring-applied brake.

In order to meet this requirement and purpose, all the persons dealing with the assembly and the operation of the brake (qualified according to 2.1.2) have to **completely and thoroughly read** these instructions before carrying out their respective activities (assembly, commissioning, operation, maintenance, etc.). Furthermore, said persons of course have to **observe and implement the given instructions** when carrying out their respective activities. The instructions themselves must be accessible any time (even after completion of the respective activity) and within short time in a clean, complete and well legible condition.

Despite careful and thorough elaboration of the instructions, mistakes, defects and incompleteness in the operating and assembly instructions cannot be excluded. For this reason, please consult M/s. PRECIMA if in doubt. Other technical questions, notes and suggestions for improvement can also be directed to the following address:

The logo for PRECIMA, featuring the word "PRECIMA" in a large, bold, blue font with a stylized 'C' that has a square cutout.

MAGNETTECHNIK GmbH

Röcker Straße 16

D – 31675 Bückeberg

Telefon Nr.: +49 (0) 57 22 / 89 33 2 -0

Telefax Nr.: +49 (0) 57 22 / 89 33 2 -2

E-mail: info@precima.de

1.3 Terms and Identification of Notices

Important notices in Chapter 4 (Assembly), Chapter 5 (Operation) and Chapter 6 (Disassembly / Exchange) referring to technical security as well as to industrial safety are particularly highlighted by the following **signal words**:

- è Danger!** Refers to processes and operation procedures which are to be thoroughly observed in order to exclude a **hazard to persons**.
- è Attention!** Refers to safety measures which must absolutely be followed in order to **avoid brake failures**.
- è Stop!** Refers to instructions that have to be **particularly observed** when carrying out the work described.

In order to simplify the text of these operating and assembly instructions, certain longer and complicated terms are replaced by shorter ones which will have the following meanings in the scope of these instructions:

Instructions = Operating and assembly instruction

Working brake = Brake which implements friction work in regular operation, i.e. performs a braking function

Brake = Spring-applied brake = electromagnetically released spring-applied brake

Data sheet = Technical data sheet

Holding brake = Brake which does not perform friction work in regular operation but merely holds the load in position. In case of an emergency, however, it may also perform a braking function.

End plate = Motor end plate = end plate of an electric motor

Dimension sheet = Dimension drawing

PRECIMA = M/s. PRECIMA = PRECIMA Magnettechnik GmbH, Bückeberg

Shaft = Motor shaft = shaft of an electric motor

In the scope of these operating and assembly instructions, the spring-applied brake is considered to be a machine element to be connected to an electric motor since this combination represents the most frequently used variant. Accordingly, certain designations refer to said fact (motor shaft, motor end plate è see above). However, this is no general limitation of the validity of these instructions to such combinations - just as there is no comparable limitation to the application of the spring-applied brake at all.

2. Conditions for Assembly and Operation

2.1 Persons

2.1.1 Operator

Operator is that natural person or entity using the spring-applied brake or instructing the spring-applied brake to be used. The operator and/or a person assigned by him must safeguard the **proper use according to 2.3** and the observance of relevant standards and provisions, regulations and laws. In particular, he has to take care of the fact that only **qualified personnel according to 2.1.2** is entrusted with work at the brake.

2.1.2 Personnel

Personnel to carry out work at the brake must exclusively be qualified personnel who - based upon their education, experience, instructions as well as knowledge concerning relevant standards and provisions, accident prevention, regulations and operating conditions - have been authorised by the person being responsible for safety, to carry out the activities described in these instructions and who - when doing so - are in a position to recognise possible risks early and to avoid them.

2.2 Product

2.2.1 Area of Application

The area of application of the brake is limited to plants and machines and is defined by the **general operating conditions** stated in **2.2.4** as well as by the boundary conditions, performance data and dimensions indicated in the **dimension drawing** and on the **name plate (lettering) of the brake** (see: **3.1**). Any deviation from these directives require a particular agreement with PRECIMA. Particularly pay attention to the application as a **working** and an application as a **holding brake** (definition: see 1.3).

2.2.2 Environment of Application

The environment of application of the spring-applied brake must be designed such that after its proper assembly the brake may fulfil its function in perfect operation and will not pose any risk for persons and material assets. Changes in the environment of application (e.g. at the machine or plant which the brake is connected with) must only be carried out, if they have no influence on the first mentioned condition.

2.2.3 State of Application

The permissible state of application of the brake includes the operationally perfect state of all components (in case of worn parts: exchange in time) and the observance of the operating and assembly requirements specified in these instructions as well as the omission of any retrofits, changes or modification of the brake, unless authorised by PRECIMA. The latter also includes the use of only original spare and exchange parts.

è Attention!

Friction surfaces and the friction lining should not under any circumstances be in contact with oil or grease since already small quantities reduce the braking torque considerably!

2.2.4 General Operating Conditions

Operating time: 100%
Ambient temperature: -20...+40°C

Should any of the above parameters be exceeded . M/s. PRECIMA should be contacted for advice.

2.3 Proper Use

At the time of delivery, the spring-applied brake represents the state of the art technology, and is generally considered to be reliable in operation. Only use it **properly** in order to avoid any risk to persons and material assets.

The spring-applied brake is properly used, if qualified personnel (according to 2.1.2) by applying the valid operating and assembly instructions (as per 1.1, according to 1.2) **produces and maintains** a permissible state of application (according to 2.2.3) in an admissible environment of application (according to 2.21).

The improper (inappropriate) use includes hazards which could not be completely taken into account when designing and construction the brake and which are unforeseeable in this sense.

2.4 Legal Aspects

2.4.1 Liability

On the basis of the information, data and directions given and of the illustrations and descriptions included in these operating and assembly instructions, no claims for brakes outside the area of application of these instructions (compare 1.1) may be submitted.

In general, an inappropriate use of the brake (compare 2.3) will exclude the liability of M/s. PRECIMA.

2.4.2 Warranty

For the warranty terms refer to the General Terms of Sales and Delivery of M/s. PRECIMA (www.precima.de / AGB). In all cases, warranty claims are to be submitted to PRECIMA immediately after establishing a deficiency or a defect. The exclusion of liability according to 2.4.1 simultaneously means that no warranty claim exists.

2.4.3 Directives and Standards

The spring-applied brake was produced in accordance with the following EC directives and standards:

- EC Directive Machinery (2006/42 EC)
- EN ISO 12100-1 and 12100-2: Safety of Machinery (Basic Concepts)
- EC Directive Electromagnetic Compatibility (2004/108 EG). Compliance with this directive has to be safeguarded with the appropriate switchgear of the user.

The spring-applied brake is not an independently operable machine but intended to be installed in other machinery. Its commissioning is prohibited until the establishment is reached that the machines comply with the provisions of the EC Directive.

2.5 Delivery Scope and State

Check the delivery scope and state **immediately upon receipt of the brake.**

M/s. Precima will not assume any warranty for subsequently claimed defects (refer to 2.4.2).

Immediately report damage in transit to the forwarders and the incompleteness of the delivery and visible defects to the manufacturer plant.

è Attention!

Should any uncertainties or discrepancies occur during the examination or should the delivery be incomplete or defective, the brake must not be installed or commissioned without previously contacting PRECIMA.

3. Product Description

3.1 Labelling

3.1.1 Lettering

The lettering of the spring-pressure brake includes all important data. These data and the contractual provisions for the brakes establish the limits of their use.

Lettering on the brake housing:

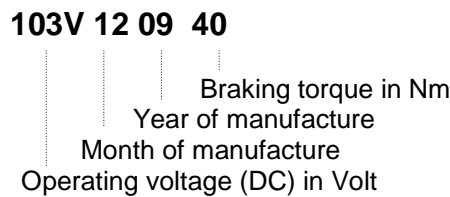

3.1.2 Type Designation Code

Example:

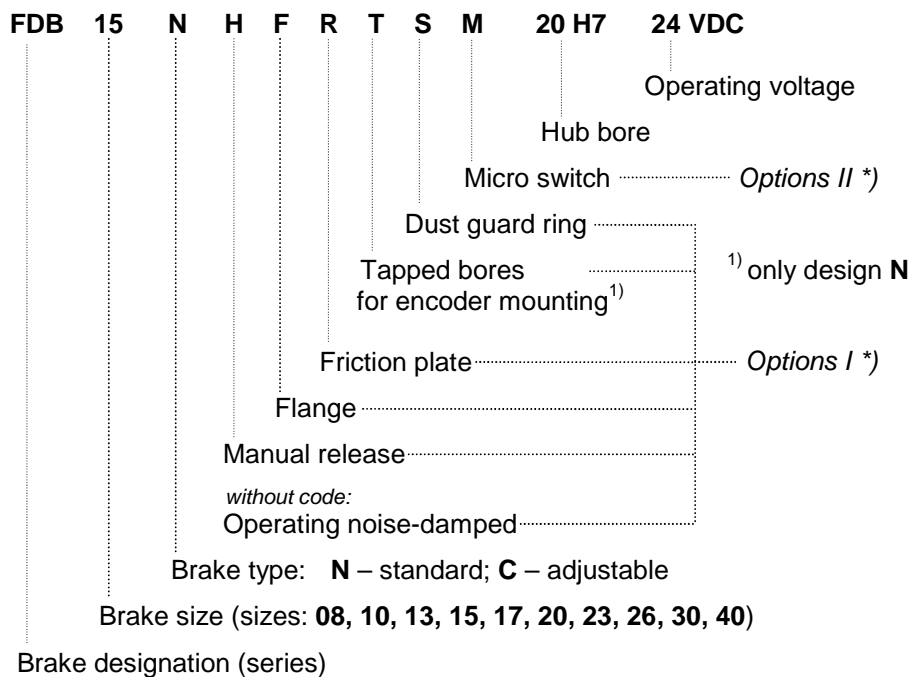

*) The *Options I* are specified in this Operating and Installation Instructions. These options, if required, have to be indicated at the time of order (e.g. by using the code)

**) The *Options II* are *not* specified in this Operating and Installation Instructions. At FDB series it is only the option M (=Micro switch). This option, if required, has also to be indicated at the time of order and it is not retrofittable. There are separate Operating and Installation Instructions for Options II which have to be observed.

3.2 Technical Information

3.2.1 Operation of the Brake (Illustration 3.1)

The electromagnetically released spring-applied brakes of the FDB series are fail-safe brakes, this means that the braking torque is generated by means of spring force, and released by magnetic force.

During **braking**, the pressure springs (item **4**, illustration 3.1) apply pressure to the armature plate (item **2**) trapping the rotor (item **3.1 / 3.2**) which is keyed to the machine shaft, against the counter-friction surface (flange (item **7**), friction plate (item **8**) or motor flange). The two friction sides of the rotor and the armature disk and/or the counter-friction surface produces the braking torque.

During **releasing**, a magnetic force is produced through applying a direct voltage to the magnet body (item **1.1 / 1.2**) via the field winding. Said magnetic force draws the armature disk (item **2**) to the magnet body and the brake rotor is released.

During **manual releasing** (*only if brakes are designed with manual release*), the armature disk is mechanically pulled against the magnet body by pulling the manual release handle (item **5**, with screwed-in manual releasing lever (item **5.1**)) and thus the rotor is released. This enables you to release the brake, for example, even if there is a power failure.

è Attention!

For safety reasons, the adjustment of the manual release must not be changed!

Illustration 3.1:
Operation of the brake (sectional view)

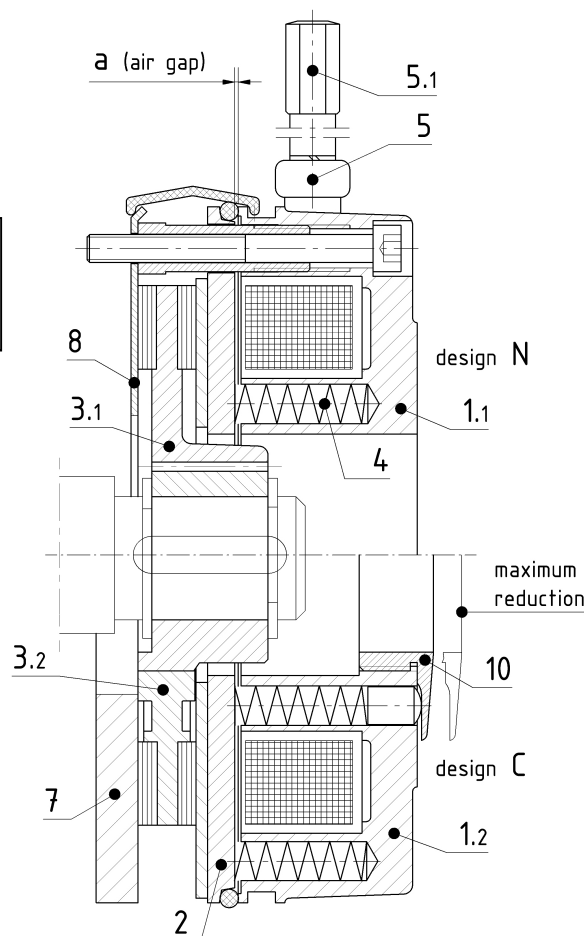

Brake type N (Illustration 3.1 top)

The standard type of the spring-pressure brake is delivered with a fixed braking torque M_{bN} . Via the number of springs (item 4), this torque can be varied as per 3.2.2.1.

Brake type C (Illustration 3.1 bottom)

The braking torque for this brake type with central adjusting ring (item 10) is also adjustable via the number of springs as per 3.2.2.1 similar to type N. Furthermore, it can additionally be adjusted by **screwing in and screwing out the adjusting ring**. The *nominal* braking torque has been adjusted as soon as the ring firmly contacts the magnet housing (item 1.2). Screwing out will result in a step-by-step reduction of the braking torque as per 3.2.2.2.

3.2.2 Technical Data

3.2.2.1 Nominal braking torques and number of springs

Size	08	10	13	15	17	20 N	20 C	23 N	23 C	26	30	40
Nominal braking torques M_{bN} [Nm]	7,5*	15*	30*	60*	90*	150*	150*	225*	225*	375*	600*	1500*
	5	10	20	40	60	100	100	150	150	250	400	1000
	3,5	7	14	28	43	70	80	107	105	187	300	850
	3	6	12	23	34	57	50	85	63	125	200	675
	2	4	8	17	26	42		65				500

* only with holding brake possessing emergency-stop properties

— Permissible deviations of the real braking torque:
 Working brake: -30% (new) or ±20% (run-in)
 Holding brake: ±20% (new) or -10/+30% (run-in) —

Size	08	10	13	15	17	20 N	20 C	23 N	23 C	26	30	40
Number of springs for the above M_{bN}	— Please, ask for spring quantities for nominal braking torques deviating from M_{bN} —											
	7	7	7	7	7	7	8	7	8	8	8	12
	5	5	5	5	5	5	6	5	6	6	6	10
	4	4	4	4	4	4	4	4	4	4	4	8
	3	3	3	3	3	3		3				6

3.2.2.2 Torque reduction (design C)

Size	08 C	10 C	13 C	15 C	17 C	20 C	23 C	26	30	40	
Torque reduction / latching step [Nm]	0,2	0,2	0,3	1	1,3	1,5	2	<i>no standard design C</i>			
Number of usable latching steps (max. permissible turning out the threaded ring)	6	12	12	9	12	18	24				

3.2.2.3 Dimensions, masses, attachment (illustration 3.2)

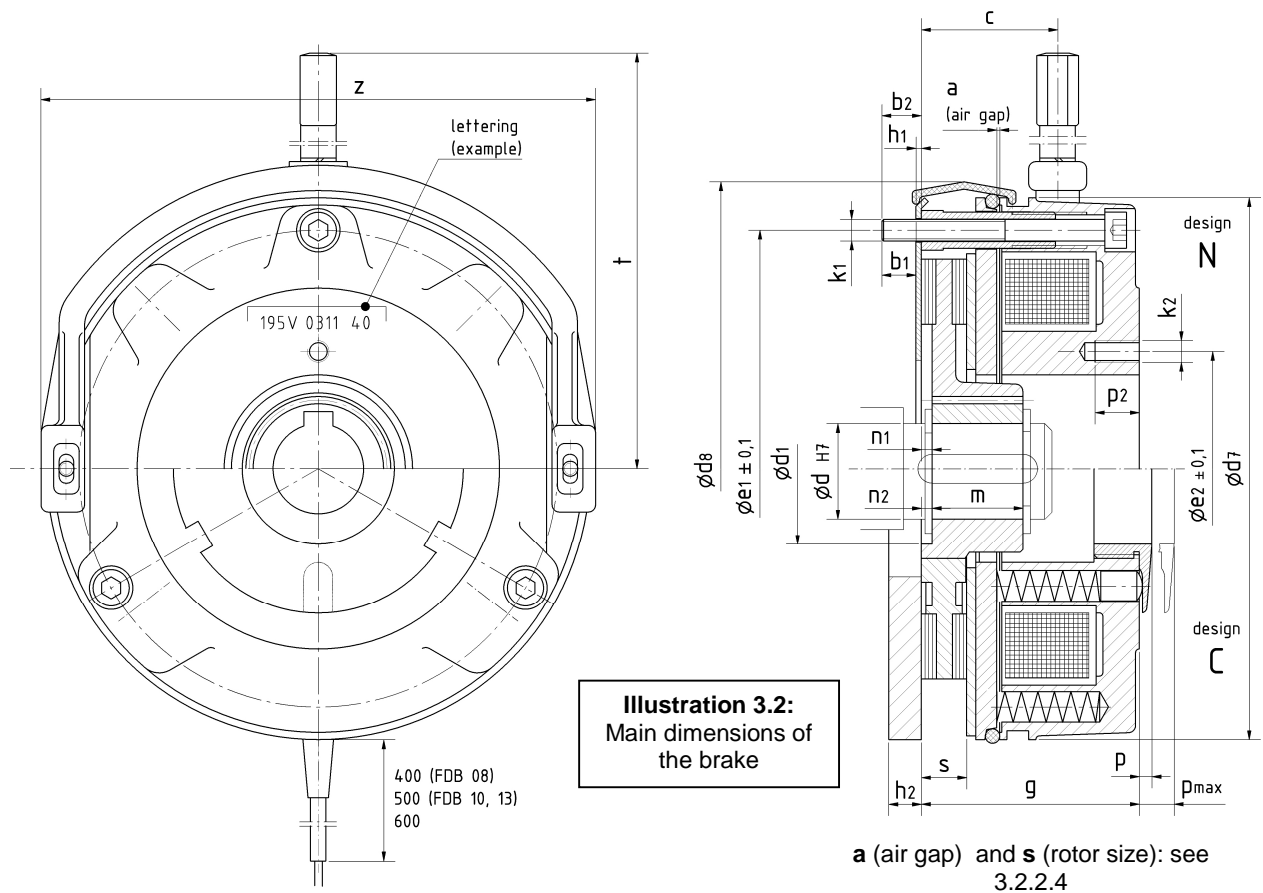

Size	Hub dimensions [mm]						General brake dimensions [mm]						Dimensions of tapped bores [mm] - only design N -		
	Hexagon hub Ød ^{H7}	Toothed hub Ød ^{H7}	Mounting dimensions			Brake without / with dust guard ring	Brake in new condition	Brakes with manual release			Hole circle Øe1 ±0,1	(Bore qty.) x thread-nom.-Ø	thread depth		
	<i>d</i>	<i>d</i>	<i>d</i> ₁	<i>m</i>	<i>n</i> ₁	<i>n</i> ₂	<i>d</i> ₇ / <i>d</i> ₈	<i>g</i> / <i>h</i> ₁ / <i>h</i> ₂	<i>c</i>	<i>t</i>	<i>z</i>	<i>e</i> ₂	<i>k</i> ₂	<i>p</i> ₂	
08	11/14/15	11/14*/15*	20	18	1,5	0,5	85 / 89	40 / 1,5 / 6	22	100	89	34	(3 x) M4	8	
10	15/19/20*	14/15	25	20	2,5	1	105 / 109	48 / 1,5 / 7	21	110	111	40	(3 x) M5	12	
13	15/20/25	15/20	33	20	3,5	1,5	130 / 135	53 / 1,5 / 9	33	130	132	54	(3 x) M6	12	
15	20/25/30	20/25	42	25	3	2	150 / 155	60 / 1,5 / 9	38	140	151	65	(3 x) M6	12	
17	-	25/30/35*	-	30	3	-	170 / 175	70 / 2 / 11	42	165	172	75	(3 x) M8	15	
20	-	30/35/40	-	30	3	-	195 / 201	80 / 2 / 11	48	186	196	85	(3 x) M8	15	
23	-	35/40/45	-	35	4	-	225 / 231	90 / 2 / 11	51	200	224	95	(3 x) M8	15	
26	-	40/45/50/55*	-	40	4	-	258 / 264	99 / 2 / 11	57	285	258	110	(6 x) M10	25	
30	-	50/55/60/65*	-	50	4	-	306 / 312	105/ 2 /12,5	59	310	304	138	(6 x) M10	25	
40	-	65/70/75/80*	-	70	4	-	400 / 408	120,6 / 18**	69	415	403	180	(6 x) M12	43***	

Standard feather key groove of the hub as per DIN 6885/1-JS9

* deviating feather key groove as per DIN 6885/3-JS9 // ** no option *Friction plate*; dimension *h*₂ (*Flange*)

*** separate inner pole: 15 mm without thread (through-hole)

Size	Masses [kg]			Attachment dimensions [mm]			Tightening torque [Nm]	Adjusting dimensions [mm]	
	Brake without manual release and flange	Manual release	Flange	Hole circle $\varnothing e_1 \pm 0,1$	(Bore qty.) x thread-nom.- \varnothing	Thread depth with-out / with friction plate	Fastening screws	Threaded ring (design C)	Manual release
				e_1	k_1	b_2 / b_1	M_A	$p \dots p_{max}$	y
08	1,10	0,05	0,20	72	(3 x) M4	6 / 9,5	3	3...6	1
10	1,90	0,08	0,34	90	(3 x) M5	7 / 10,5	6	3...9	1
13	3,10	0,10	0,68	112	(3 x) M6	9 / 12,5	10	3,5...9,5	1
15	4,60	0,13	0,90	132	(3 x) M6	9 / 12,5	10	3,5...8	1
17	6,30	0,17	1,40	145	(3 x) M8	11 / 14	25	4,5...10,5	1
20	10,00	0,24	1,90	170	(3 x) M8	11 / 14	25	7...14	1,2
23	14,70	0,29	2,50	196	(3 x) M8	11 / 19	25	8...17	1,2
26	21,50	0,80	3,50	230	(3 x) M10	11 / 19	50	-	1,5
30	35,00	0,90	5,20	278	(6 x) M10	19 / 17	50	-	1,5
40	60,00	0,90	13,10	360	(6 x) M12	17 / 19**	85	-	1,5

** no option *Friction plate*; thread depth for option *Flange*

Dimension *y* see 4.3.2 or illustration 4.2

3.2.2.4 Air gaps, rotor values

Size	Nominal air gap [mm]	max. air gap [mm]		Rotor size (new state) [mm]	Rotor size (minimum) [mm]	Mass moment of inertia rotor [kgm ²]	Max. speed rotor [min ⁻¹]	
	a_{nenn}	a_{max}		s_{neu}	s_{min}		n_{max}	n_{max} rotor weighed heavy
08	0,2 ^{+0,15}	0,60	0,45*	7,5 ^{-0,1}	4,5	0,015 x 10 ⁻³	6000	
10	0,2 ^{+0,15}	0,70	0,45*	8,5 ^{-0,1}	5,5	0,045 x 10 ⁻³	6000	
13	0,3 ^{+0,15}	0,80	0,55*	10,3 ^{-0,1}	7,5	0,173 x 10 ⁻³	6000	
15	0,3 ^{+0,15}	0,90	0,60*	12,5 ^{-0,1}	9,5	0,45 x 10 ⁻³	6000	
17	0,3 ^{+0,15}	1,00	0,60*	14,5 ^{-0,1}	11,5	0,86 x 10 ⁻³	3600	6000
20	0,4 ^{+0,15}	1,10	0,80*	16,0 ^{-0,1}	12,5	1,22 x 10 ⁻³	3600	6000
23	0,4 ^{+0,15}	1,10	0,80*	18,0 ^{-0,1}	14,5	2,85 x 10 ⁻³	3600	6000
26	0,5 ^{+0,2}	1,20	0,90*	20,0 ^{-0,1}	16,5	6,65 x 10 ⁻³	1500	3000 / 6000*
30	0,5 ^{+0,2}	1,20	0,90*	20,0 ^{-0,1}	16,5	19,5 x 10 ⁻³	1500	3000 / 6000*
40**	0,6 ^{+0,2}	1,20	1,20*	22,0 ^{-0,1}	18,5	44,5 x 10 ⁻³	1500	3000 / 6000*

* Holding brakes with emergency-stop properties

** Switched with fast acting rectifier (over-excitation)

3.2.2.5 Friction work, friction capacity

Size	Max. permissible friction capacity** [J/h]	Max. permissible friction work / braking [J]	Max. permissible friction capacity** [J/h]	Max. permissible friction work / braking [J]	Friction work / 0.1 mm wear [J]
	Working brake		Holding brake		***
	P_{Rmax}	W_{Rmax}^*	P_{Rmax}	W_{Rmax}^*	$Qr_{0,1}$
08	288×10^3	3×10^3	144×10^3	1.5×10^3	16×10^6
10	360×10^3	6×10^3	180×10^3	3×10^3	30×10^6
13	468×10^3	12×10^3	234×10^3	6×10^3	42×10^6
15	576×10^3	25×10^3	288×10^3	12×10^3	70×10^6
17	720×10^3	35×10^3	360×10^3	17×10^3	85×10^6
20	900×10^3	50×10^3	450×10^3	25×10^3	140×10^6
23	1080×10^3	75×10^3	540×10^3	37×10^3	170×10^6
26	1260×10^3	105×10^3	630×10^3	52×10^3	230×10^6
30	1440×10^3	150×10^3	720×10^3	75×10^3	310×10^6
40	1620×10^3	200×10^3	810×10^3	100×10^3	400×10^6

* at $W_R] 0,1 * W_{Rmax}$ the rotor speed and the braking time (discrete braking) must be considered (è consultation with PRECIMA is required)!

** in case of a uniform timely distribution of brakings

*** with sizes 08...13: Lining HT; with sizes 15...40: Lining HD

3.2.2.6 Electrical specific values

Size	Electric power (average) [W]	Voltage [VDC]	Nominal current (guide value) [A]	Size	Electric power (average) [W]	Voltage [VDC]	Nominal current (guide value) [A]
	$P_{20^\circ C}$	U	I_N		$P_{20^\circ C}$	U	I_N
08	22	24	0,92	20	85	24	3,30
		103	0,25			103	0,86
		180	0,12			180	0,46
		205	0,11			205	0,44
10	28	24	1,17	23	76	24	3,20
		103	0,31			103	0,86
		180	0,16			180	0,40
		205	0,13			205	0,34
13	34	24	1,42	26	105	24	4,17
		103	0,38			103	1,12
		180	0,19			180	0,60
		205	0,15			205	0,54
15	45	24	1,69	30	140	24	5,90
		103	0,46			103	1,36
		180	0,25			180	0,78
		205	0,24			205	0,68
17	55	24	2,18	40	144	—	—
		103	0,59			—	—
		180	0,30			180	0,77
		205	0,28			205	0,73

3.2.2.7 Switching times

Size	Nominal braking torque [Nm]	Separating time [ms]	Response delay [ms]	Linkage time [ms]	Response delay [ms]	Linkage time [ms]
			<i>switched on d.c. side</i>		<i>switched on a.c. side</i>	
	$M_{bN} =$	$t_2 =$	$t_{11DC} =$	$t_{1DC} =$	$t_{11AC} =$	$t_{1AC} =$
08	7,5*	60*	12*	32*	40*	70*
	5	35	18	38	60	90
10	15*	85*	15*	45*	80*	125*
	10	60	20	50	100	145
13	30*	125*	20*	60*	140*	200*
	20	85	25	65	220	280
15	60*	140*	18*	68*	80*	155*
	40	100	20	70	150	225
17	90*	190*	18*	78*	120*	210*
	60	120	22	82	200	290
20	150*	175*	26*	106*	160*	280*
	100	150	35	115	300	420
23	225*	290*	40*	140*	250*	400*
	150	270	45	145	320	570
26	375*	360*	46*	166*	200*	400*
	250	300	58	178	400	600
30	600*	450*	50*	180*	250*	600*
	400	400	65	195	550	900
40**	1500*	450*	120*	280*	2500*	2950*
	1000	320	160	320	3000	3450

* Holding brakes with emergency-stop properties

** Switched with fast acting rectifier (over-excitation)

— The switching times indicated are to be understood as tolerance-afflicted guide values with nominal air gap —

t_2 = separating time = time from switching on the current to cessation of braking torque ($M_b \leq 0,1 \cdot M_{bN}$)

– Over-excitation by fast acting rectifier results in approx. half the separating times –

t_{1DC} = linkage time = response time when braking with interruption at d.c. side by mechanical switches = time from switching off current to reaching the full braking torque ($M_b \geq 0,9 \cdot M_{bN}$)

t_{1AC} = linkage time = response time when braking with shutdown at a.c. side, i.e. by interrupting a separately supplied rectifier

t_{11DC} / t_{11AC} = response delay = time from switching off current to the rising of the braking torque (included in the respective linkage time)

– Depending on operating temperature and wear of the brake disks, the real response times (t_2 , t_{1DC} , t_{1AC}) may deviate from the guide values indicated here. In case of a voltage reduction by a fast acting rectifier, there will be reduced linkage times –

4. Assembly

4.1 Mechanical Installation

4.1.1 Prerequisites and Preparation

- When unpacking the spring-applied brake check for damage, and missing parts (according to delivery note). Complaints regarding damages in transit have to be immediately made with the supplier, complaints of missing parts or short supply have to be made with PRECIMA (also refer to 2.5).
- Compare the data on the name plate of the brake with the suppliers invoice and customers order.

è Attention!

Should the checks result in any uncertainties or discrepancies, the brake must not be installed and commissioned without prior consultation with PRECIMA.

4.1.2 Counter-friction surface

4.1.2.1 Motor endsheid or adaptor, etc. as counter-friction surface

- Check whether the existing counter-friction surface meets the relevant requirements (material: steel, steel casting, grey cast iron - *no aluminium / stainless steel with limitations* - surface quality **Rz 6.3** and whether it is free from grease and oil.

4.1.2.2 Flange, friction plate

- If the counter friction surface is supplied in the form of a flange (item **7**, **illustration 4.1**) or a friction plate (item **8**), first of all flange or friction plate have to be bolted to the motor (independent of the brake). The thread of the screws to be used corresponds with the thread of the fastening screws of the brake. The hole pitch circles must be identical as well. *In general, it is also possible to do without this screw connection, however, for reasons of performance this approach and practice is not recommended by M/s. PRECIMA particularly with regard to the friction plate.*

è Attention!

Should the counter-friction surface not meet the relevant requirements, the brake must not be installed and commissioned without prior consultation with PRECIMA. Completely remove grease and oil from the counter-friction surface before processing the brake further!

4.1.3 Hub and rotor (illustration 4.1)

è Stop!

Before actually mounting the rotor, its thickness has to be checked in accordance with 3.2.2.4. s_{new} is the value for a new rotor (tolerance = 0/-0.1 mm), s_{min} is the minimum permissible rotor thickness. When installing a new rotor, $s = s_{\text{new}}$ must be guaranteed. In case of a reassembly (e.g. after a dismantling caused by maintenance work), $s > s_{\text{min}}$ must be guaranteed, otherwise the rotor has to be replaced.

The rotor is fixed to the motor shaft and revolves with the motor shaft and brakes the shaft when power is removed from the brake:

- Insert the first circlip (item **14**) into the rear radial groove of the shaft
- Insert the feather key (item **15**) into the axial groove of the shaft
- Push the toothed hub (item **6.1**) or the hexagon hub (item **6.2**) onto the shaft and over the feather key
- Axially fix the hub by inserting the second circlip (item **16**) into the front radial groove of the shaft
- Push the rotor (item **3.1** or **3.2**) onto the hub. The rotor must be able to move axially on the hub.

è **Attention!** Pay attention to the smooth running of the rotor/hub pair!

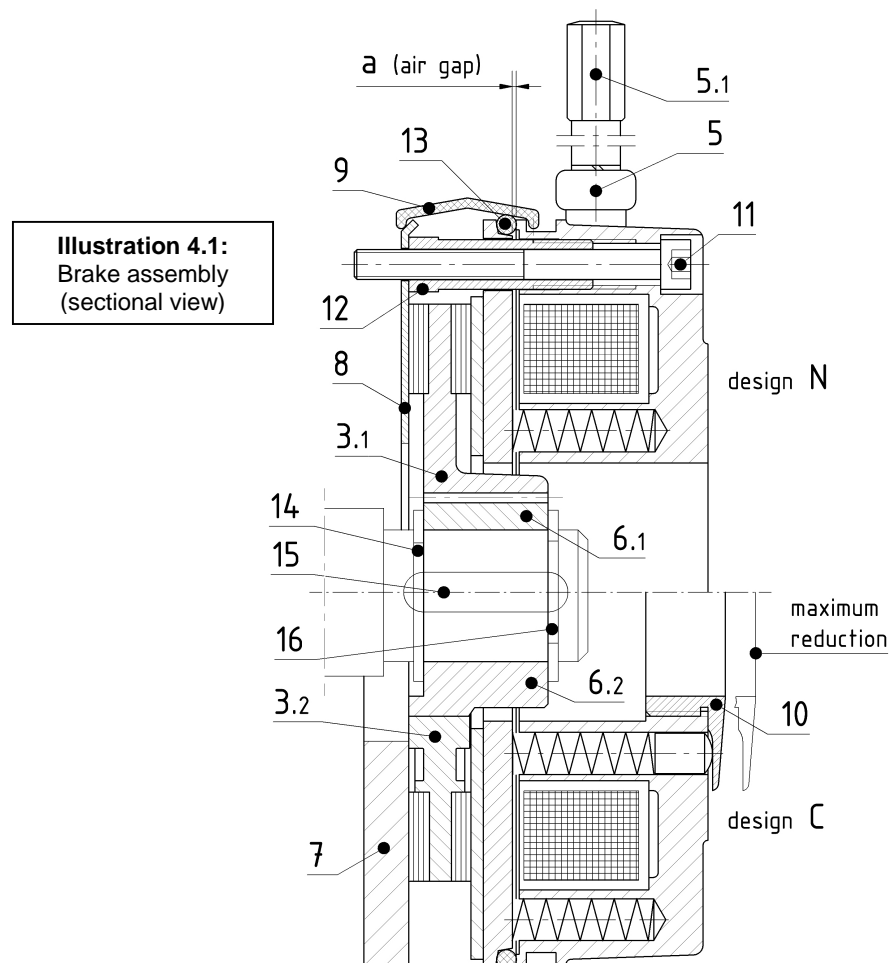

4.1.4 Brake (illustration 4.1)

The brake is attached to the flange or to the motor flange (if this is the counter-friction surface or if a friction plate is used). The important adjustments need to be made for safe operation of the brake, if necessary, the brake will be supplemented by additional component parts:

- Fit the brake onto the rotor, insert the fastening screws (item **11**) until hollow screws (item **12**) rest on the counter-friction surface.
- Check the size of air gap **a** in order to keep the **nominal value** (+ tolerance) by means of a feeler gauge at three positions on the circumference and, if necessary, correct it by turning the hollow screws (for values of nominal air gap and tolerance: see **3.2.2.4**).
è How to proceed in order to correct the air gap refer to **5.1.3.1**.

- Tighten the fastening screws with the tightening torque according to **3.2.2.3**
- Position the O-ring (item **13**; *only for brakes with option "Operating noise-damped"*)
- Position the dust ring (item **9**; *only for brakes with option S*)
- Screw the manual release lever (item **5.1**) with the washer in position into manual release bracket (item **5**) and tighten it at the hexagon faces (*only brakes with manual release = option H*)
- Adjust the braking torque by means of the threaded ring (item **10**). Adjusting values: refer to **3.2.2.2** (*only brakes according to design C*)

4.2 Electrical Installation

Carry out the electrical connection with power off. The operating voltage (DC) of the brake is indicated on the magnet housing (see 3.1.1 and illustration 3.2).

è Stop! For the electrical connection the detailed instruction „Electrical connection of PRECIMA Spring-Applied Brakes“ has to be observed!

4.3 Conversions and Supplements

4.3.1 Change of Braking Torque

A change of the braking torque (with design C in addition to the adjusting ring as per 3.2.2.2) can be carried out by changing the number of springs according to table **3.2.2.1**. In doing so, pay attention to the uniform distribution of the externally arranged springs.

4.3.2 Subsequent Assembly of Manual Release (illustration 4.2)

Brakes that were directly ordered as brakes with a manual release (option H), have already a manual release mounted and the adjustment must not be changed (refer to safety information undsr 3.2.1).

A manual release handle can be fitted by the customer using the procedure below:

- Place the manual release handle (item **5**) onto the magnet body (item **1.1 / 1.2**) and insert the two pins with cross threaded hole (item **23**) in the appropriate bores of the manual release handle.
- Insert the screw (item **20**) with the washer in position (item **21**) and the pressure spring (item **22**) into the bores of the armature disk. The screws will pass through the armature plate and magnet body; the washer is positioned between the head of the screw and the armature plate. The pressure spring runs through the armature and is held by the washer and magnet body on the other side.
- Screw the screws into the pins (item **23**) and adjust the dimension **y** according to **3.2.2.3**. **Lock** both screws in the correct adjusting position **by means of screw sealing wax**.

è Attention!

For safety reasons, the adjustment of the manual release must not be changed even after a subsequent mounting by the customer! A readjustment of the braking air gap a (refer to 5.1.3.1) does not require any adjustment of dimension y!

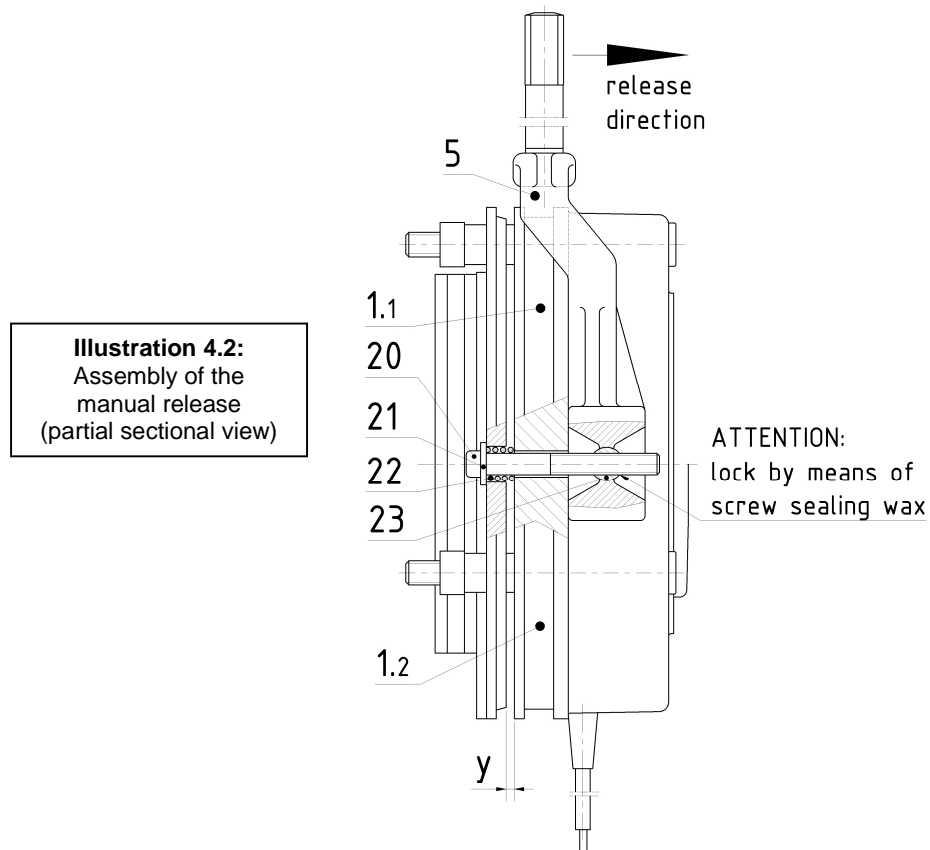

5. Operation

5.1 Brake in Operation

5.1.1 Commissioning

Before commissioning the brake, a **functional test** has to be carried out. This can normally be carried out together with the motor & brake attached. For possible malfunctions refer to: 5.2.

è Stop!

The complete braking torque will only be effective after the brake linings at the rotor have run in! è For deviation values to M_{DN} : see 3.2.2.1

5.1.2 Running Operation

Without any malfunctions occurring, the running operation does not require any maintenance except for checking the **size of the air gap** (this increases as the lining on the rotor wears). This has to be checked in accordance with the following schedule (also refer to 5.1.3), unless a particular sensor for wear monitoring has been included in the brake. In case of malfunctions, proceed according to 5.2.

Check intervals:

Working brake:

- + according to service life calculation
- + according to specifications made by the customer

- Holding brake:**
- + at least every two years
 - + according to specifications made by the customer
 - + use shorter intervals in case of frequent emergency stops

Furthermore, check the **rotor size s** after a number of re-adjustments of the air gap a (see 5.1.3). A suitable control interval results from the relation of the difference $s_{neu} - s_{min}$ to difference $a_{nenn} - a_{max}$ considering the respective tolerances.

5.1.3 Maintenance

5.1.3.1 Readjusting the air gap (illustration 5.1)

The spring-applied brake is virtually maintenance-free. However, when the **maximum air gap** stated under 3.2.2.4 is reached, a **re-adjustment (new adjustment) of the air gap a** will be required for the safe operation of the brake. The functional capability of the brake which may in certain cases go beyond the maximum air gap does not change the aforesaid requirement: **“a proper use” will no longer exist in such a case.** In this case, functional capability and safety function of the brake will be compromised with a further increase in wear.

How to proceed when readjusting the air gap:

- Viewing in direction of the brake (see **illustration 5.1**) loosen the fastening screws (item **11**) by turning them half a rotation *counter-clockwise*.
- Turn the hollow screws (item **12**) into the magnet body by also turning them *counter-clockwise*.
- Turn the fastening screws (*clockwise*) into the (motor) flange until the *nominal* air gap is reached (to be measured with feeling gauge) at three positions on the circumference.
- Reset the hollow screws, i.e. turn them out of the magnet body (*clockwise*) until locked against the counter-friction surface.
- Tighten the fastening screws with the **tightening torque as per 3.2.2.3.**
- Subsequently control of the air gap, if necessary, carry out a readjustment

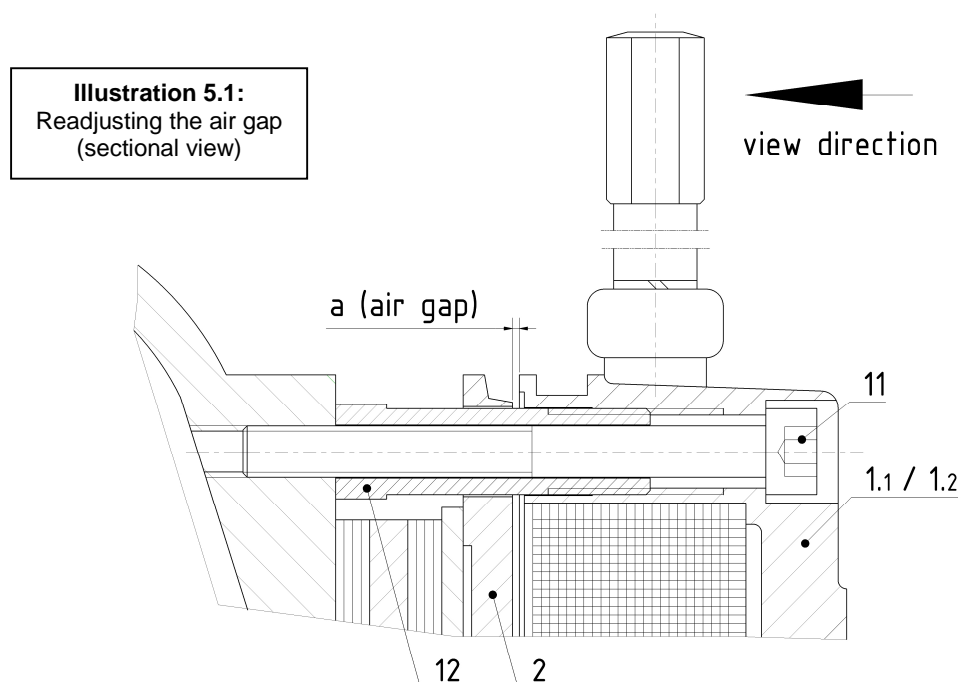

5.1.3.2 Replace the rotor

When the minimum rotor size s_{\min} according to 3.2.2.4 is reached, a re-adjustment of the air gap “a” is no longer possible and the rotor has to be replaced. An operative readiness of the brake in certain cases falling below the minimum rotor size does not change the above statement; **in such a case “a proper use” is no longer existing.**

è Stop!

Even after an exchange of the rotor, the complete braking torque will only be effective after the brake linings at the rotor have run in!

è For deviation values to M_{bN} : see 3.2.2.1

è Attention!

During the task of replacing the rotor, all the mechanical parts associated with the transmission of the braking torque have to be checked for excessive wear (armature disc, hollow screws) and/or integrity (springs) and, if required, to be replaced!

5.2 Brake out of Operation (Malfunctions)

The following table includes typical problems during commissioning or running in, their possible causes and instructions on solving them.

Malfunction	Possible causes	Solution
Brake does not release	Air gap too large	Check and readjust air gap
	Brake is not supplied with voltage	Check electrical connection
	Voltage at the coil too low	Check the supply voltage of the coil
	Armature plate obstructed	Remove obstruction
Brake releases with delay	Air gap too large	Check and readjust air gap
	Voltage at the coil too low	Check the supply voltage of the coil
Brake does not apply	Voltage at the coil too large	Check the supply voltage of the coil
	Armature plate obstructed	Remove obstruction
Brake applies with delay	Voltage at the coil too large	Check the supply voltage of the coil

6. Disassembly / Exchange

6.1 Removing the Brake

Removing the brake is the reverse of the assembly must only be done with the brake and motor being **switched off, de-energised and torque-free**.

è Danger!

The disassembly of the brake will result in a suspension of its holding torque. No risks must be taken with said suspension!

6.2 Exchange of Components

The only component to be regularly exchanged on site is the **rotor** when it reaches the wear limit (refer to 5.1.3.1); and if the **hub** shows signs of noticeable wear, it may be exchanged as well. Furthermore, however, all the other components indicated under **6.4 Spare Parts** may generally be exchanged.

è Attention!

Before any re-assembly of the brake, check the fastening screws for damage and, if necessary, exchange them!

6.3 Exchange of Brake / Disposal

Because of the different material components, the components of our spring-applied brakes have to be disposed of for recycling separately. Moreover, pay attention to the official regulations. Important AAV (List of Wastes Ordinance) key numbers are indicated below. Depending on the material connection and the kind of separation, other key numbers may apply to components made of such materials.

- Ferrous metals (key number 160117)
- Non-ferrous metals (key number 160118)
- Brake linings (key number 160112)
- Plastics (key number 160119)

6.4 Spare Parts

Illustration 6.1 shows all the spare parts that you can order for the spring-pressure brakes of the FDB series indicated in the list below it.

When ordering spare parts, please always state the data from the brake lettering (see 3.1.1)!

è Attention!

For damage caused by other than original spare parts and accessories any liability and warranty on behalf of PRECIMA Magnettechnik GmbH shall be excluded (refer to 2.3.3).

Illustration 6.1:
Spare parts
(Sectional view)

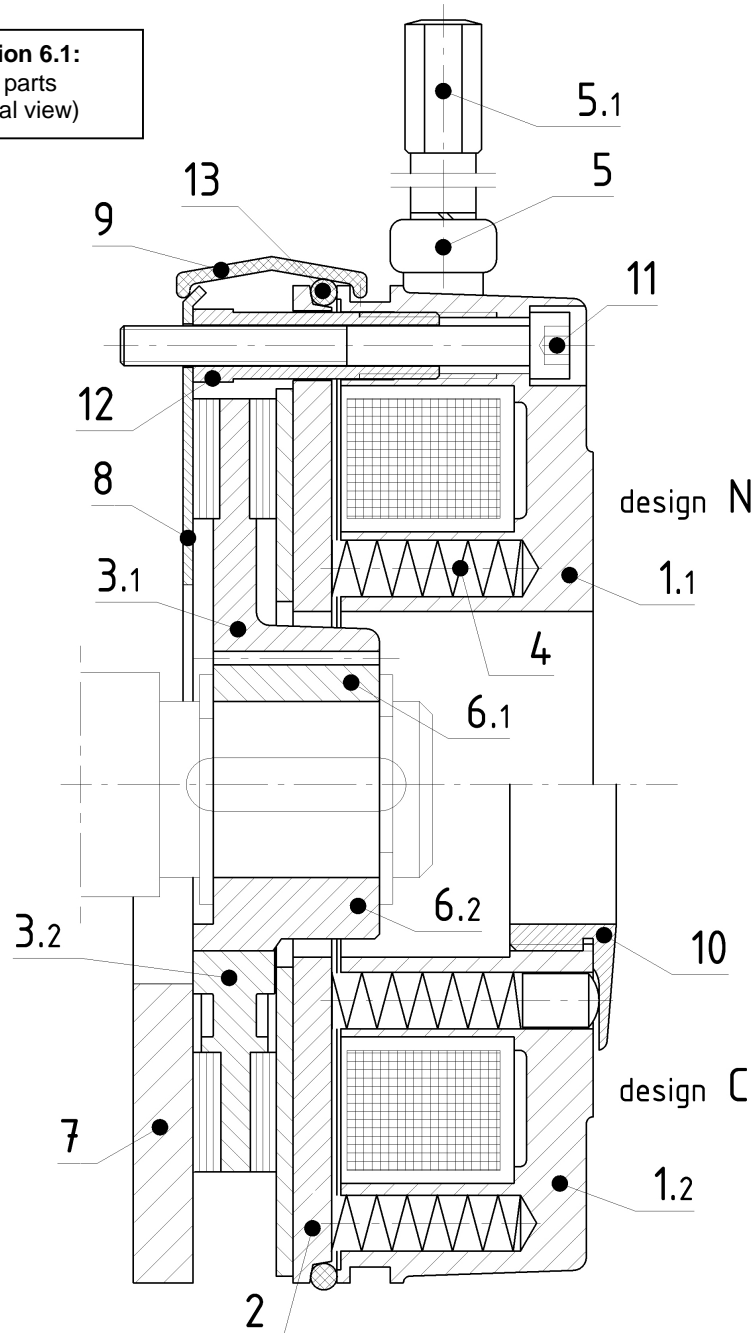

Item	Designation	Item	Designation
1.1	Magnet part cpl. design N	6.2	Hub for rotor 3.2
1.2	Magnet part cpl. design C	7	Flange
2	Armature plate	8	Friction plate
3.1	Rotor cpl. (Alu design)	9	Dust guard ring
3.2	Rotor cpl. (plastic design)	10	Adjusting ring
4	Springs	11	Fastening screw
5	Manual release cpl.	12	Hollow screws
5.1	Manual release lever	13	O-ring
6.1	Hub for rotor 3.1		