

# EK1

## WITH KEYWAY CONNECTION

0.5 - 2,150 Nm



### PROPERTIES

#### FEATURES

- ▶ press fit design
- ▶ readily modified for custom dimensions
- ▶ low backlash (keyway)

#### MATERIAL

- ▶ **Hubs:** up to size 450 high strength aluminum; size 800 steel
- ▶ **Elastomer:** wear resistant thermally stable TPU

#### DESIGN

Two concentrically machined hubs with curved jaws, keyways, and set screws.

**Optional:**  
Conical bores for Fanuc motors and other tapered shafts available.

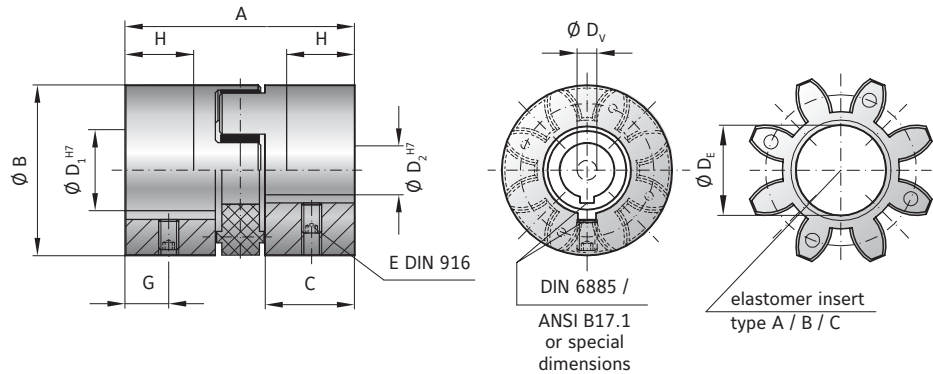

## MODEL EK1

SIZE	2			5			10			20			60			150			300			450			800		
Type (Elastomer insert)	A	B	C	A	B	C	A	B	C	A	B	C	A	B	C	A	B	C	A	B	C	A	B	C	A	B	C
Rated torque (Nm) $T_{KN}$	2	2.4	0.5	9	12	2	12.5	16	4	17	21	6	60	75	20	160	200	42	325	405	84	530	660	95	950	1100	240
Max. torque (Nm) $T_{Kmax}$	4	4.8	1	18	24	4	25	32	6	34	42	12	120	150	35	320	400	85	650	810	170	1060	1350	190	1900	2150	400
Overall length (mm) A	20			34			35			66			78			90			114			126			162		
Outside diameter (mm) B/B <sub>1</sub>	15			25			32			42			56			66.5			82			102			136.5		
Mounting length (mm) C	6.5			12			12			25			30			35			45			50			65		
Inside diameter (pilot bored) (mm) D <sub>v</sub>	3			4			6			7			9			14			16			22			29		
Inside diameter range H7 (mm) D <sub>1/2</sub>	3 - 9			6 - 15			6 - 18			8 - 25			12 - 32			19 - 38			20 - 45			28 - 60			32 - 80		
Inside diameter of elastomer (mm) D <sub>e</sub>	6.2			10.2			14.2			19.2			26.2			29.2			36.2			46.2			60.5		
Set screws (DIN 916) E	see table (depending on bore Ø)**																										
Distance (mm) G	3			5			6			9			11			12			15			17			30		
Possible shortening length (mm) H	4			6			6			19			22			26			32			37			43		
Moment of inertia per hub (10 <sup>-3</sup> kgm <sup>2</sup> ) J <sub>1</sub> /J <sub>2</sub>	0.0001			0.001			0.003			0.02			0.06			0.1			0.4			1.1			12		
Approx. weight (kg)	0.008			0.03			0.08			0.15			0.35			0.6			1.1			1.7			11		
Speed standard (min <sup>-1</sup> )	15,000			15,000			13,000			12,500			11,000			10,000			9,000			8,000			4,000		
Speed balanced (10 <sup>3</sup> min <sup>-1</sup> )	60	67	45	57	65	43	53	63	40	45	60	35	31	31	25	22	26	18	22	26	16	16	17	12	13	13	8

For information on shaft misalignment, torsional stiffness, and other details about the elastomer inserts see handbook precision couplings pages 72 + 73.

** set screw size							
D <sub>1</sub> /D <sub>2</sub>	- Ø 10	Ø 10.1 - 12	Ø 12.1 - 30	Ø 30.1 - 60	Ø 60.1 - 95	Ø 95.1 - 130	Ø 130.1 - 170
E	M3	M4	M5	M8	M10	M12	M16

# GENERAL INFORMATION

## R+W ELASTOMER COUPLINGS

### AXES OF MISALIGNMENT

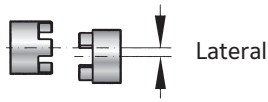

Lateral

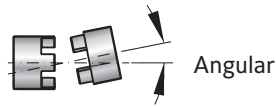

Angular

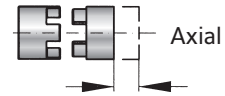

Axial

### FUNCTION

The equalizing element of the EK coupling is the elastomer insert. It transmits torque without backlash or vibration. The elastomer insert defines the characteristics of the entire drive system.

Backlash is eliminated by the press fit of the elastomer into the hubs. Through variation of the Shore hardness of the elastomer insert, the coupling system can be optimized for the ideal torsional characteristics.

### SIZES 2 - 800



A

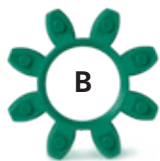

B

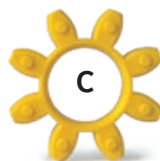

C

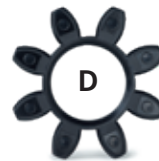

D



E

Shore hardness 98 A

Shore hardness 64 Sh D

Shore hardness 80 Sh A

Shore hardness 65 Sh D

Shore hardness 64 Sh D

### SIZES 2500 - 9500

THE COUPLING INCLUDES 5X ELASTOMER SEGMENTS

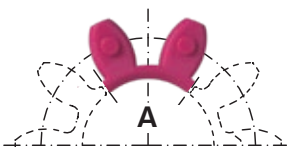

A

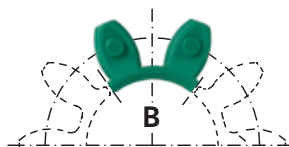

B

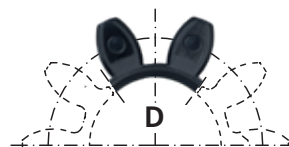

D

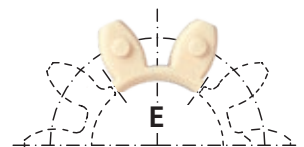

E

Shore hardness 98 Sh A

Shore hardness 64 Sh D

Shore hardness 65 Sh D

Shore hardness 64 Sh D

## DESCRIPTION OF THE ELASTOMER INSERTS

Type	Shore hardness	Color	Material	Relative damping ( $\Psi$ )	Temperature range	Features
A	98 Sh A	red	TPU	0.4 - 0.5	-30°C to +100°C	high damping
B	64 Sh D	green	TPU	0.3 - 0.45	-30°C to +120°C	high torsional stiffness
C	80 Sh A	yellow	TPU	0.3 - 0.4	-30°C to +100°C	very high damping
D*	65 Sh D	black	TPU	0.3 - 0.45	-10°C to + 70°C	electrically conductive
E	64 Sh D	beige	Hytrel	0.3 - 0.45	-50°C to +150°C	temperature resistant

\* The electrical conductivity of the elastomer material is to prevent the electrostatic charging of the elastomer coupling system, to reduce the risk of sparking in operation. ATEX technical data is available upon request.

The values of the relative damping were determined at 10 Hz and +20° C.

## SIZES EK

SIZE		2			5			10			20			60			150		
Type (Elastomer insert)		A	B	C	A	B	C	A	B	C	A	B	C	A	B	C	A	B	C
Static torsional stiffness (Nm/rad)	$C_T$	50	115	17	150	350	53	260	600	90	1140	2500	520	3290	9750	1400	4970	10600	2000
Dynamic torsional stiffness (Nm/rad)	$C_{Tdyn}$	100	230	35	300	700	106	541	1650	224	2540	4440	876	7940	11900	2072	13400	29300	3590
Lateral (mm)	Max. values	0.08	0.06	0.2	0.08	0.06	0.2	0.1	0.08	0.22	0.1	0.08	0.25	0.12	0.1	0.25	0.15	0.12	0.3
Angular (Degree)		1	0.8	1.2	1	0.8	1.2	1	0.8	1.2	1	0.8	1.2	1	0.8	1.2	1	0.8	1.2
Axial (mm)		±1			±1			±1			±1.5			±1.5			±1.8		

SIZE*		300			450			800			2500		4500		9500	
Type (Elastomer insert)		A	B	C	A	B	C	A	B	C	A	B	A	B	A	B
Static torsional stiffness (Nm/rad)	$C_T$	12400	18000	3000	15100	27000	4120	41300	66080	10320	87600	109000	167000	372000	590000	670000
Dynamic torsional stiffness (Nm/rad)	$C_{Tdyn}$	23700	40400	6090	55400	81200	11600	82600	180150	28600	175000	216000	337000	743000	1180000	1340000
Lateral (mm)	Max. values	0.18	0.14	0.35	0.2	0.18	0.35	0.25	0.2	0.4	0.5	0.3	0.5	0.3	0.6	0.4
Angular (Degree)		1	0.8	1.2	1	0.8	1.2	1	0.8	1.2	1.5	1	1.5	1	1.5	1
Axial (mm)		±2			±2			±2			±3		±3		±4	

Static torsional stiffness at 50%  $T_{KN}$

Dynamic torsional stiffness at  $T_{KN}$

\* Note: The technical values for elastomer inserts D and E correspond to the values for B, due to the identical Shore hardness.