

Rev	Description	Date	Name

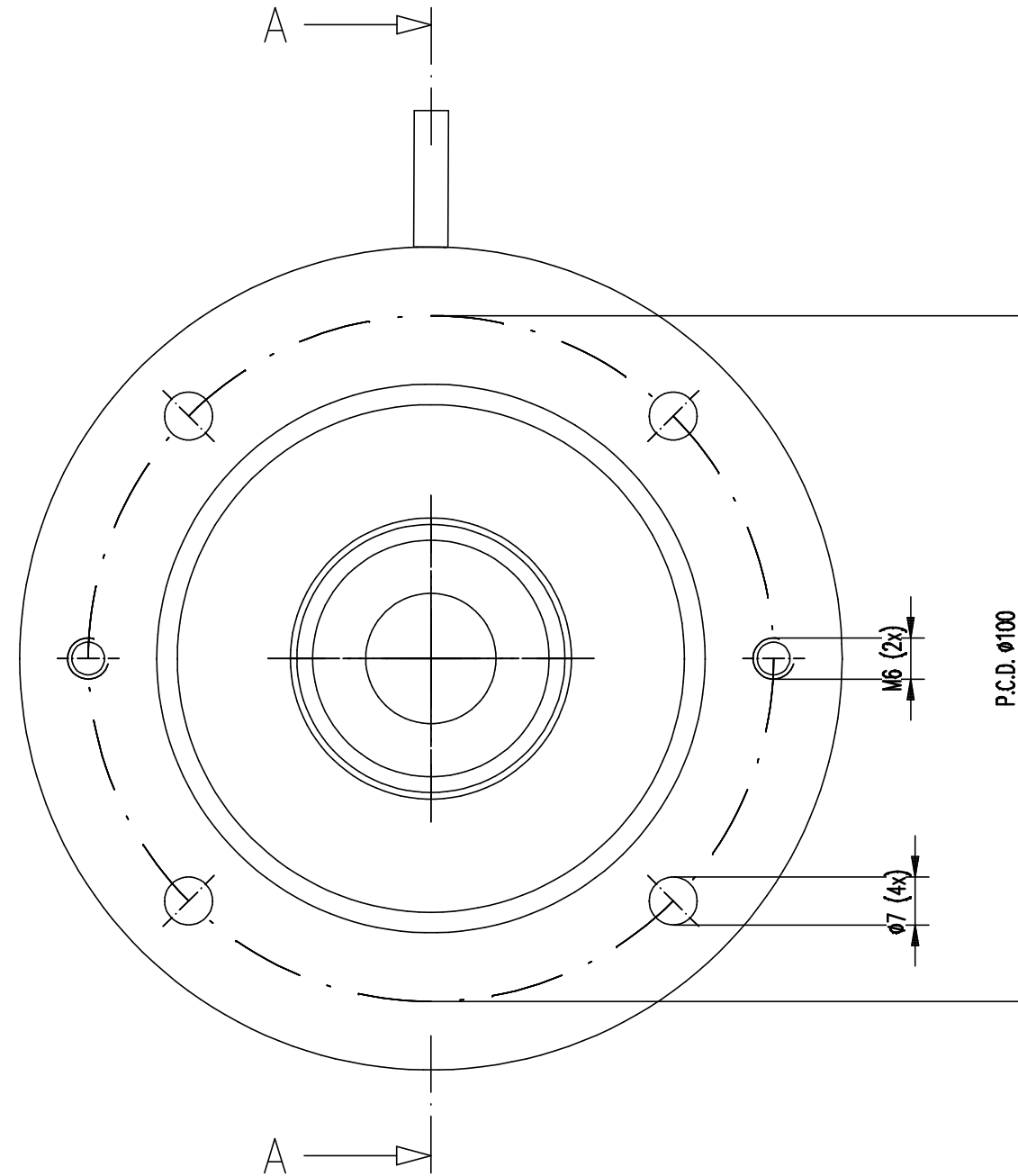
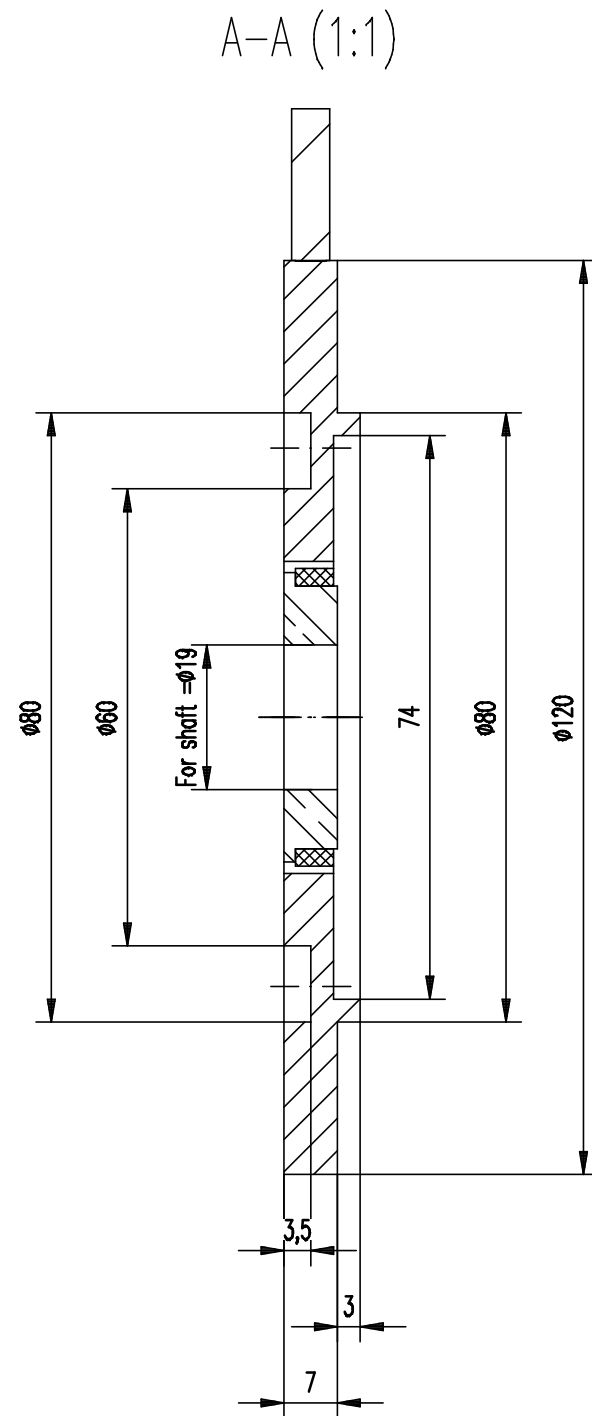

		MODEL. NO.	MATERIAL	WN.	<p>BEGE Aandrijftechniek B.V. BEGE Power Transmission Anton Philipsweg 30 2171 KX Sassenheim Nederland T +31 252-220220 F +31 252-218484 bege@bege.nl www.bege.nl</p>
REV	WEIGHT	DESCRIPTION	DRAWN	CHECKED	
SCALE	DIMENSIONS	MIG Nova+ Flange $\phi 120/7$ Shaft $\phi 19$	KSR 09.07.2020	KSR 13.07.2020	
1:1	mm		DRW. NO. DN-0009689		
FORMAT	SH.NO.	ART. NO.	ERP ART. NO.	REF. DRW.	General tolerance DIN-ISO 2768 1-m / 2-K
A3		AN-0006335			Surface

Copyright BEGE, whose property this document remains. No part may be disclosed, duplicated or in any other way made use of except with the written approval of BEGE. All rights reserved.