

BK2

WITH CLAMPING HUB

15 - 10,000 Nm

PROPERTIES



FEATURES

- ▶ easy to mount
- ▶ Optional: bolt tensioning system in size 800 and up
- ▶ light weight and low moment of inertia

DESIGN

Two clamping hubs concentrically mounted to flexible bellows. Brief overloads of up to 1.5x the rated torque are acceptable.

MATERIAL

- ▶ **Bellows:** high grade stainless steel
- ▶ **Hubs:** see table

NEW

Advantage: reduce screw tightening torques by up to 90% by using multiple smaller screws to create the same tension.

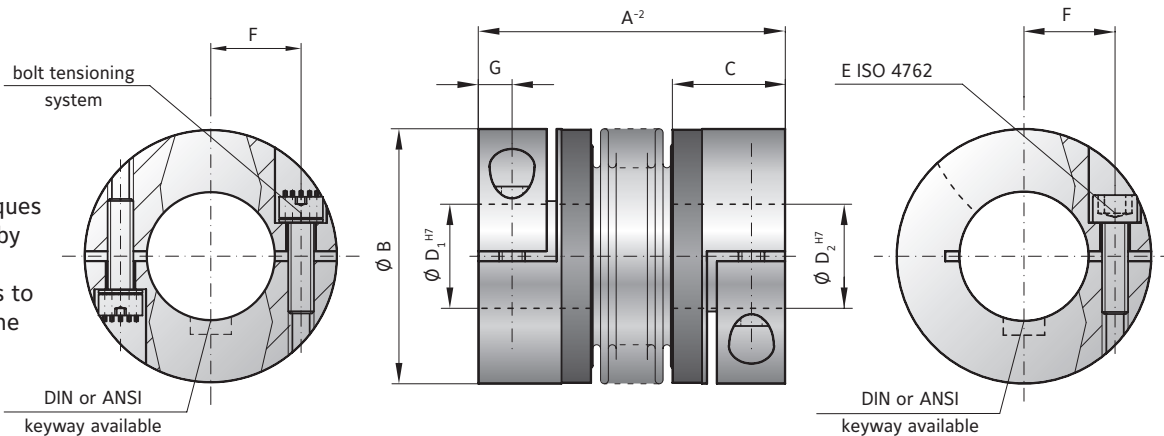

MODEL BK2

SIZE		15	30	60	80	150	200	300	500	800	1500	4000	6000	10000
Rated torque (Nm)	T_{KN}	15	30	60	80	150	200	300	500	800	1500	4000	6000	10000
Overall length (mm)	A^{-2}	59 66 99	69 77 113	83 93 130	94 106 143	95 107 144	105 117 163	111 125 200	133 146 169	140 179	166 230	225	252	288
Outside diameter (mm)	B	49	55	66	81	81	90	110	124	134	157	200	253	303
Fit length (mm)	C	22	27	31	36	36	41	43	51	45	55	85	107	129
Inside diameter possible from \emptyset to \emptyset H7 (mm)	D_1/D_2	8-28	10-30	12-35	14-42	19-42	22-45	24-60	35-60	40-75	50-80	50-90	60-140	70-180
Fastening screw ISO 4762	E	M5	M6	M8	M10	M10	M12	M12	M16	2x M16*	2x M20*	2x M24*	2x M24*	2x M30*
Tightening torque of the fastening screw (Nm)	E	8	15	40	50	70	120	130	200	250	470	1200	1200	2400
Distance between centerlines (mm)	F	17	19	23	27	27	31	39	41	2x48	2x55	2x65	2x90	2x117
Distance (mm)	G	6.5	7.5	9.5	11	11	12.5	13	16.5	18	22.5	28	35	42
Moment of inertia (10^{-3} kgm ²)	J_{ges}	0.06 0.07 0.08	0.12 0.13 0.14	0.32 0.35 0.4	0.8 0.85 0.9	1.9 2 2.1	3.2 3.4 3.6	7.6 7.9 8.3	14.3 14.6 14.8	16.2 17	43 45	165	495	1214
Hub material		Al optional steel	Al optional steel	Al optional steel	Al optional steel	steel optional AL	steel optional AL	steel optional AL	steel optional AL	steel	steel	steel	steel	steel
Approximate weight (kg)		0.16	0.26	0.48	0.8	1.85	2.65	4	6.3	5.7	11.5	28.8	49.4	80.9
Torsional stiffness (10^3 Nm/rad)	C_T	20 15 14	39 28 27	76 55 54	129 85 84	175 110 97	191 140 135	450 350 340	510 500 400	780 711	1304 1180	3400	5700	10950
Axial \pm (mm)	Max. values	1 2 3	1 2 3	1.5 2 3	2 3 4	2 3 4	2 3 4	2.5 3.5 4.5	2.5 3.5 4.5	3.5 4.5 4.5	3.5 4.5 4.5	3.5	3	3
Lateral \pm (mm)		0.15 0.2	0.2 0.25 1	0.2 0.25 1	0.2 0.25 1	0.2 0.25 1	0.25 0.3 1	0.25 0.3 1	0.3 0.35 1	0.35 1 0.35	1 0.4	0.4	0.4	0.4
Angular \pm (degree)		1 1.5 2	1 1.5 2	1 1.5 2	1 1.5 2	1 1.5 2	1 1.5 2	1 1.5 2	1 1.5 2	1 1.5 2	1.5 2 1.5	2 1.5	1.5	1.5
Axial spring stiffness (N/mm)	C_a	25 15 84	50 30 118	72 48 165	48 32 144	82 52 130	90 60 280	105 71 605	70 48 85	100 285 320	440 565	1030	985	
Lateral spring stiffness (N/mm)	C_r	475 137 140	900 270 224	1200 420 337	920 290 401	1550 435 500	2040 610 750	3750 1050 1200	2500 840 614	2000 1490 3600	1700 6070	19200	21800	

* 180° opposed in each clamping hub.