

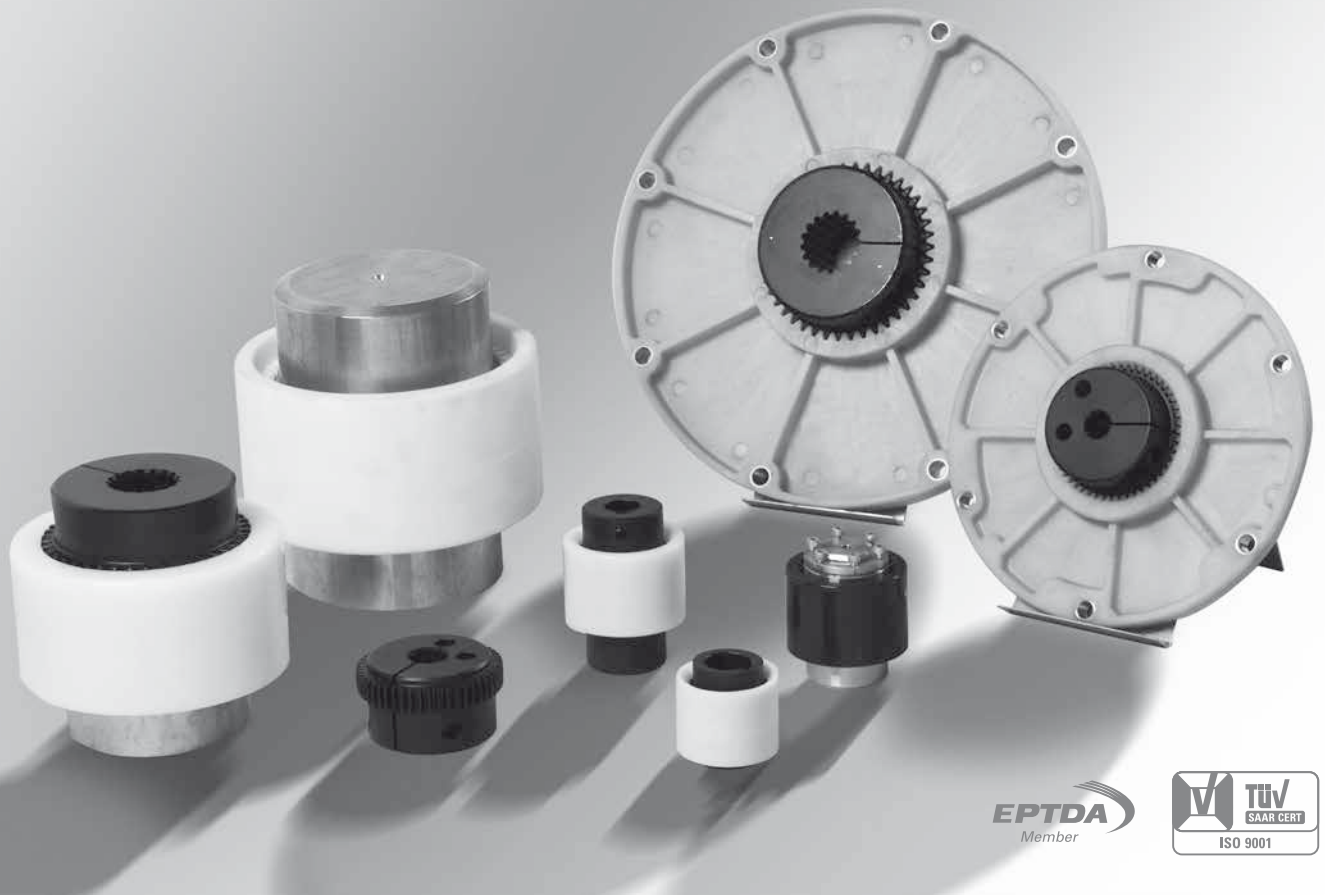

# R+L HYDRAULICS

HYDRAULIC COMPONENTS · POWER TRANSMISSION · OIL COOLERS



## BMA 0008 Instruction and Installation Manual DENTEX®

- Compensation of axial, radial and angular misalignment of shafts through double cardanic action
- Simple and easy assembly
- High electrical insulating property
- High thermal stability
- No maintenance

R+L HYDRAULICS GmbH Friedrichstr. 6 58791 Werdohl	DENTEX® operating / installation manual	Number: BMA0008 Page: 1 von 14 Version: 1ENG
---	---	--

## **Table of contents:**

<b>1.0 General information:</b> .....	<b>3</b>
1.1 Safety and information symbols: .....	3
1.2 General hazard warnings: .....	3
<b>2.0 Intended use:</b> .....	<b>4</b>
<b>3.0 Storage</b> .....	<b>4</b>
<b>4.0 Dimensions:</b> .....	<b>5</b>
4.1 DENTEX® tooth coupling .....	5
Figure 1: Diagram of the DENTEX® tooth coupling, series B .....	5
Table 1: Dimensions of the DENTEX® tooth coupling, series B .....	5
4.2 DENTEX® tooth coupling, series B4R & B3R .....	6
Figure 2: Diagram of the DENTEX® tooth coupling, series B4R with external stop rings and Seeger rings .....	6
Table 2: Dimensions of the DENTEX® tooth coupling, series B4R .....	6
Figure 3: Diagram of the DENTEX® tooth coupling, series B3R with internal and external Seeger rings .....	7
Table 3: Dimensions of the DENTEX® tooth coupling, series B3R .....	7
<b>5.0 Assembly</b> .....	<b>8</b>
5.1 Assembly instructions .....	8
5.2 Components of the coupling .....	8
Figure 4: DENTEX® tooth coupling - assembly .....	8

Copyright reserved as per ISO 16016	Signed: 05.10.2010 MBOZ Checked: 01.04.2011 JZIS	Replacement for: Replaced by:
--	---	----------------------------------

R+L HYDRAULICS GmbH Friedrichstr. 6 58791 Werdohl	DENTEX® operating / installation manual	Number: BMA0008 Page: 2 von 14 Version: 1ENG
---	---	--

Figure 5: DENTEX® tooth coupling with clamped design & heat-resistant sleeve - assembly .....	9
Figure 6: DENTEX® tooth coupling, size DT55/DT80/DT100 - assembly.....	9
Figure 7: DENTEX® tooth coupling, type B3R - assembly .....	10
Figure 8: DENTEX® tooth coupling, type B4R - assembly .....	10
5.3 Assembling the DENTEX® coupling .....	10
Table 4: Tightening torques for threaded pins .....	11
Table 5: Tightening torques for clamping screws .....	11
5.4 Additional assembly of the DENTEX® coupling, type B4R .....	11
5.5 Additional assembly of the DENTEX® coupling, type B3R .....	11
5.6 Displacement types and values .....	12
Figure 9: Displacement types and values .....	12
Table 6: Displacement values .....	13
<b>6.0 Spare parts management &amp; addresses: .....</b>	<b>13</b>
<b>7.0 Important information for Ex-zones.....</b>	<b>13</b>
<b>8.0 Additional information: .....</b>	<b>14</b>

Copyright reserved as per ISO 16016	Signed: 05.10.2010 MBOZ Checked: 01.04.2011 JZIS	Replacement for: Replaced by:
--	---	----------------------------------

R+L HYDRAULICS GmbH Friedrichstr. 6 58791 Werdohl	DENTEX® operating / installation manual	Number: BMA0008 Page: 3 von 14 Version: 1ENG
---	---	--

The DENTEX® tooth coupling has the ability to compensate for the angular, radial and axial displacement produced by manufacturing and assembly tolerances.

## **1.0 General information:**

Carefully read through this installation manual before installing the DENTEX® tooth coupling. Pay particular attention to the safety instructions!

The installation manual is part of your product. Store it carefully and in the vicinity of the DENTEX® tooth coupling.

The copyright for this installation manual shall remain with **R+L HYDRAULICS** GmbH.

### **1.1 Safety and information symbols:**



**Danger Risk of injury to personnel**



**Caution Damage could occur to the machine**



**Note Note regarding important information**



**Caution Notes / instructions on use in Ex zones**

### **1.2 General hazard warnings:**



During installation and removal of the DENTEX® tooth coupling, make sure that the entire drive train is secured to prevent accidental activation, and that the system is depressurised. Failure to handle rotating parts in the proper manner can cause serious injury. For this reason, the following safety instructions should be read and followed without exception.

- All work on the DENTEX® tooth coupling should be performed from the perspective of ->„Safety first“.
- Switch off the drive unit before carrying out work on the DENTEX® tooth coupling.
- Secure the drive unit to prevent unintentional activation, e.g. by attaching information signs to the switch-on points or removing the fuse at the power supply.
- Do not reach into the working area of the machine while it is still in operation.
- Protect the rotating parts to prevent accidental touching. Attach the relevant protective devices and covers.

Copyright reserved as per ISO 16016	Signed: 05.10.2010 MBOZ Checked: 01.04.2011 JZIS	Replacement for: Replaced by:
--	---	----------------------------------

R+L HYDRAULICS GmbH Friedrichstr. 6 58791 Werdohl	DENTEX® operating / installation manual	Number: BMA0008 Page: 4 von 14 Version: 1ENG
---	---	--

## **2.0 Intended use:**

You may only install and maintain the DENTEX® tooth coupling if you:

- have carefully read and understood the installation manual
- are authorised and trained to do so

The DENTEX® tooth coupling may only be used in accordance with the technical specifications. Unauthorised structural changes to the DENTEX® tooth coupling are prohibited. We will not accept any liability for damage occurring as a result of this. In the interest further development, we reserve the right to make technical changes. The DENTEX® tooth coupling described here corresponds with the latest technical standards at the time of publication of this installation manual. The DENTEX® tooth coupling is usually delivered ready for installation.

## **3.0 Storage**

- It should be possible to store the coupling hubs in a covered, dry place for 6 months.
- Provided that storage conditions are favourable, the properties of the coupling sleeves will remain unaltered for up to 5 years.



**The storage areas must not contain any ozone-producing devices, such as fluorescent light sources, mercury-vapour lamps, or high-voltage electrical equipment. Damp storage areas are unsuitable. Make sure that no condensation is produced. A favourable relative humidity level would be below 65%.**

Copyright reserved as per ISO 16016	Signed: 05.10.2010 MBOZ Checked: 01.04.2011 JZIS	Replacement for: Replaced by:
--	---	----------------------------------

## 4.0 Dimensions:

### 4.1 DENTEX® tooth coupling

Figure 1: Diagram of the DENTEX® tooth coupling, series B

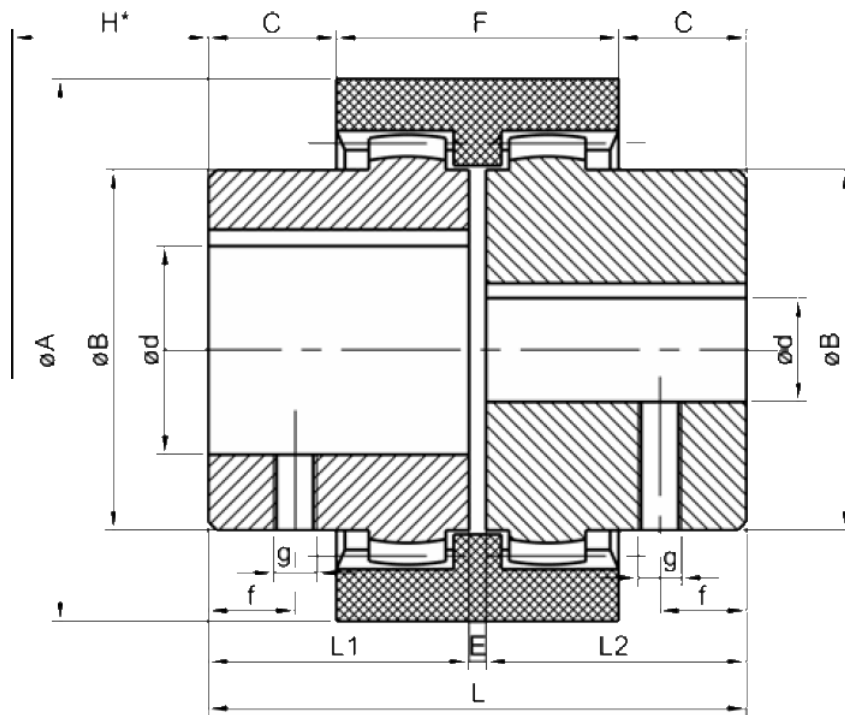
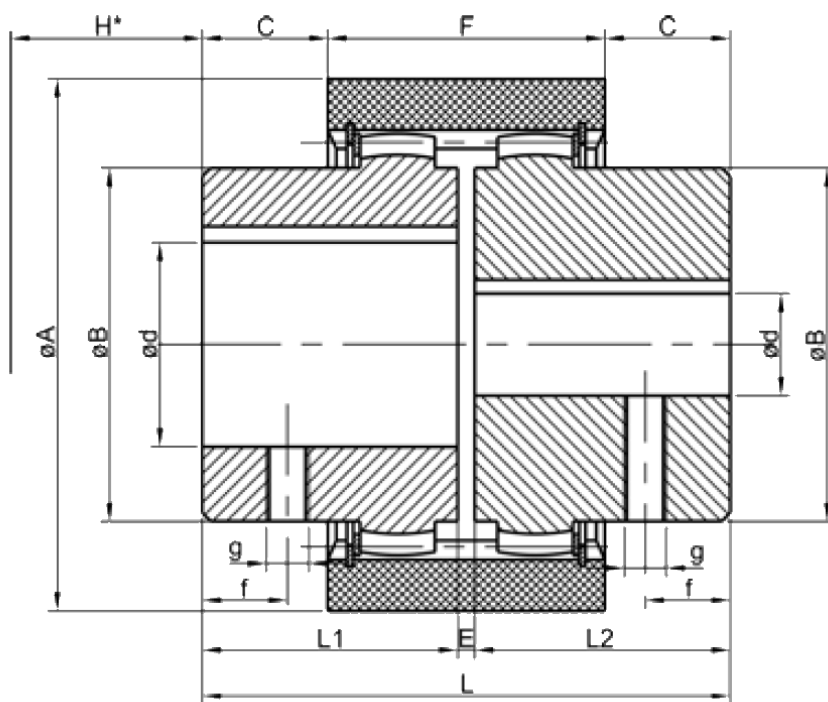

Table 1: Dimensions of the DENTEX® tooth coupling, series B

Typ Type	Vor- bohrung Pre- bored	Fertigbohrungen Finish bores d [mm]		A	B	L	L1+L2	E	H*	C	F	g	f	L2	Sonderlänge Extended hub length	Gewicht Weight kg	Massenträg- heitsmoment Moment of inertia J kg/m²
		min.	max.														
B-14	5	6	14	40	25	50	23	4	15	6.5	37	M5	6	40	-	0.175	0.000030
B-19	8	9	19	48	30	54	25	4	17	7.0	37	M5	6	-	-	0.320	0.000470
B-24	9	10	24	52	36	56	26	4	17	7.5	41	M5	6	50	-	0.316	0.000093
B-28	9	10	28	66	44	84	40	4	20	19.0	46	M8	10	55	-	0.739	0.000310
B-32	11	12	32	76	50	84	40	4	20	18.0	48	M8	10	55	-	0.950	0.000550
B-38	12	14	38	83	58	84	40	4	20	18.0	48	M8	10	60	-	1.220	0.000870
B-42	16	20	42	92	65	88	42	4	22	19.0	50	M8	10	60	-	1.490	0.001400
B-48	16	20	48	100	68	104	50	4	22	27.0	50	M8	10	60	-	1.810	0.001800
B-55	-	25	55	125	83	124	60	4	30	30.0	65	M10	20	-	-	3.450	0.004600
B-65	0/30	10/32	65	140	96	144	70	4	32	36.0	72	M10	20	-	-	5.180	0.009900
B-80	-	30	80	175	124	186	90	6	45	46.5	93	M10	20	-	-	11.50	0.037000
B-100	35	40	100	210	152	228	110	8	55	63.0	102	M12	30	-	-	20.50	0.115600

## 4.2 DENTEX® tooth coupling, series B4R & B3R

**Figure 2: Diagram of the DENTEX® tooth coupling, series B4R with external stop rings and Seeger rings**



**Table 2: Dimensions of the DENTEX® tooth coupling, series B4R**

Typ Type	Fertigbohrung Finish bores		A	B	L	L1 + L2	E	H*	C	F	g	f	Gewicht Weight kg	Massenträgheits- moment kgm²
	min.	max.												
B4R 32	12	32	84	50	84	40	4	18.0	13.0	58	M8	10	1.1	0.0007
B4R 45	20	42	100	65	88	42	4	18.0	14.0	60	M8	10	1.5	0.0017
B4R 65	25	65	140	96	144	70	4	15.0	30.0	84	M10	20	5.4	0.0118
B4R 80	30	80	175	124	186	90	6	3.5	46.5	93	M10	20	11.7	0.0385
B4R 100	40	100	210	152	228	110	8	-	63.0	102	M12	30	20.8	0.0987

**Figure 3: Diagram of the DENTEX® tooth coupling, series B3R with internal and external Seeger rings**

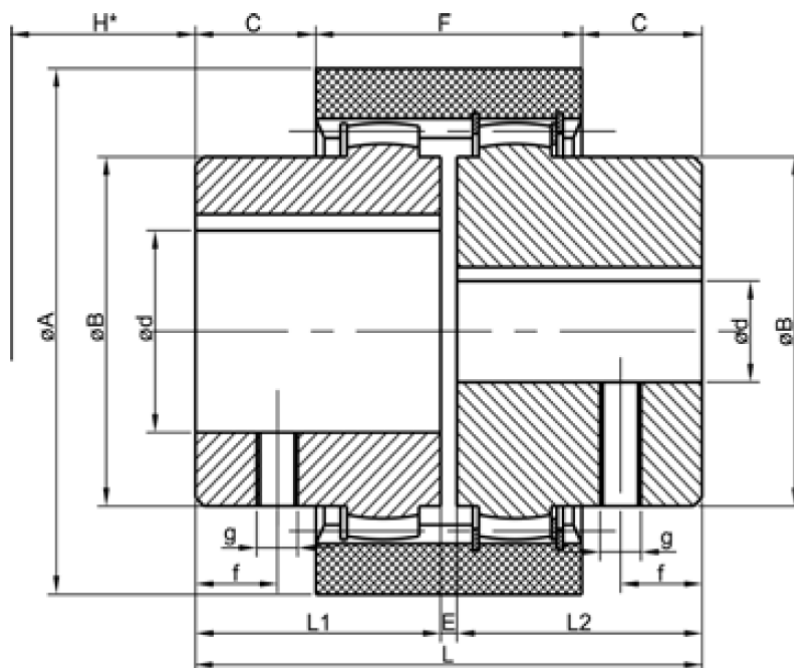

**Table 3: Dimensions of the DENTEX® tooth coupling, series B3R**

Typ Type	Fertigbohrung Finish bores		A	B	L	L1 + L2	E	H*	C	F	g	f	Gewicht Weight kg	Massenträgheits- moment Moment of inertia J kgm²
	min.	max.												
B3R 24	10	24	58	36	56	26	4	23.5	2.5	51	M5	6	0.3	0.0001
B3R 28	10	28	70	44	84	40	4	26.0	14.0	56	M8	10	0.8	0.0004
B3R 32	12	32	84	50	84	40	4	27.0	13.0	58	M8	10	1.1	0.0007
B3R 45	20	42	100	65	88	42	4	28.0	14.0	60	M8	10	1.5	0.0016
B3R 65	25	65	140	96	144	70	4	40.0	30.0	84	M10	20	5.4	0.0115
B3R 80	30	80	175	124	186	90	6	45.0	46.5	93	M10	20	11.6	0.0378
B3R 100	40	100	210	152	228	110	8	49.0	63.0	102	M12	30	20.7	0.0974



**DENTEX® tooth couplings used with other add-on parts which could produce heat, sparks and static charges (e.g. JOYTORK safety couplings) are not approved for use in Ex-zones. These must be tested in advance.**



## **5.0 Assembly**

### **5.1 Assembly instructions**



We recommend checking the dimensional accuracy of the hole, shaft, slot and feather key before commencing assembly.



Gently heating the hubs to approx. 80°C makes it easier to fit them onto the shaft.



Touching the heated coupling hubs can cause burns. Wear safety gloves.



During assembly, make sure that dimension E, see Tables 1-3, is adhered to, so that the coupling sleeve can still move axially during use. If this instruction is not observed, the coupling cannot work properly and may be damaged.



It is vital that you pay attention to hazards from ignition sources in areas where there is a risk of explosion!

### **5.2 Components of the coupling**

**Figure 4: DENTEX® tooth coupling - assembly**

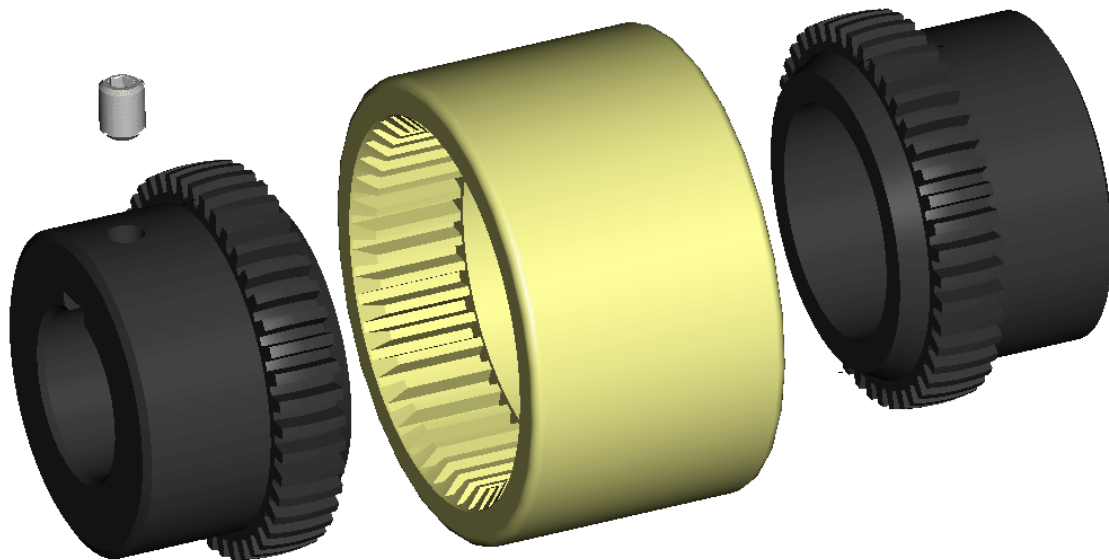

**Figure 5: DENTEX® tooth coupling with clamped design & heat-resistant sleeve - assembly**

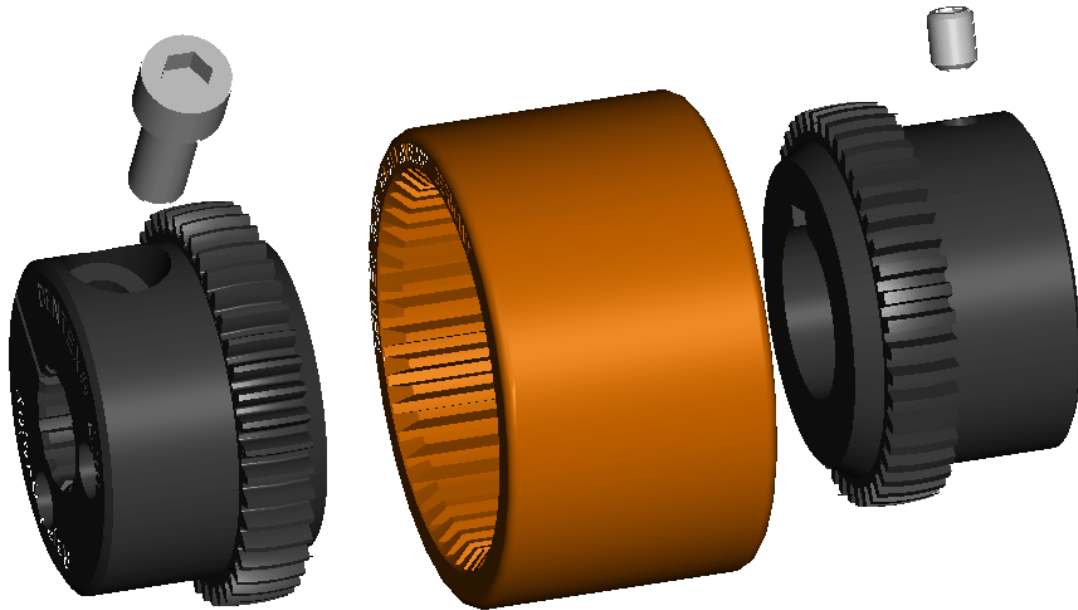

**Figure 6: DENTEX® tooth coupling, size DT55/DT80/DT100 - assembly**

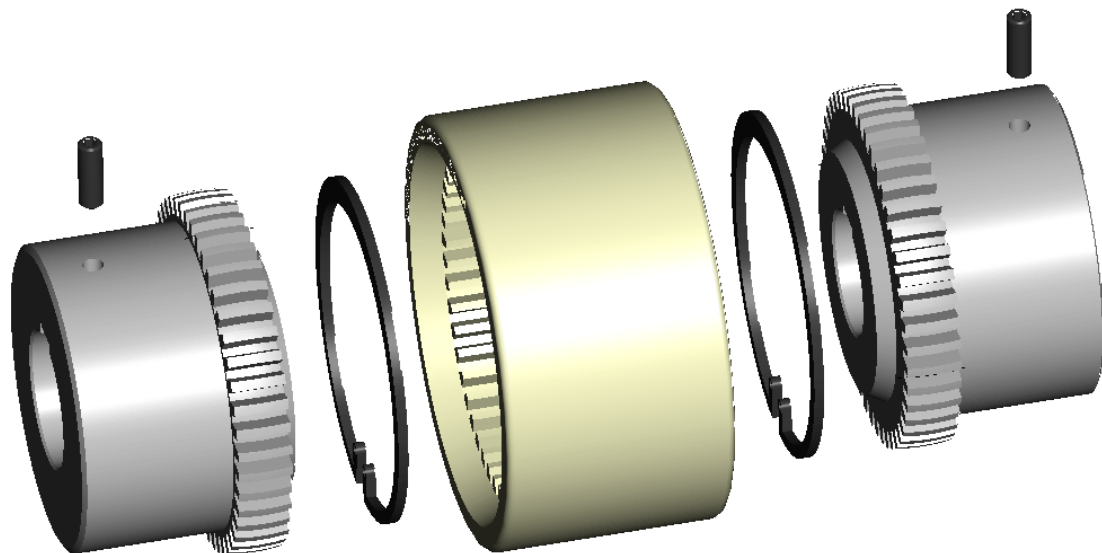

**Figure 7: DENTEX® tooth coupling, type B3R - assembly**

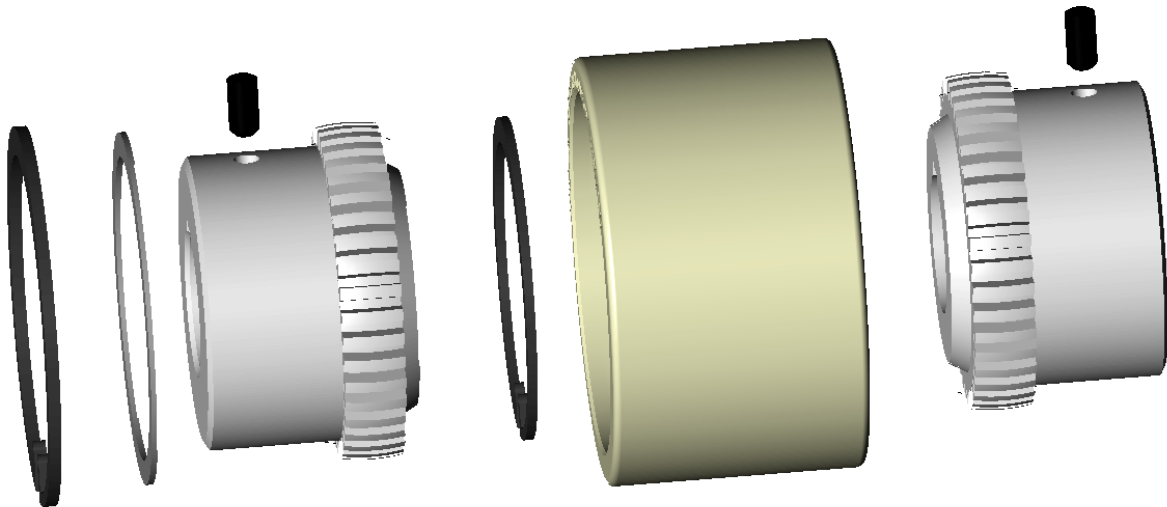

**Figure 8: DENTEX® tooth coupling, type B4R - assembly**

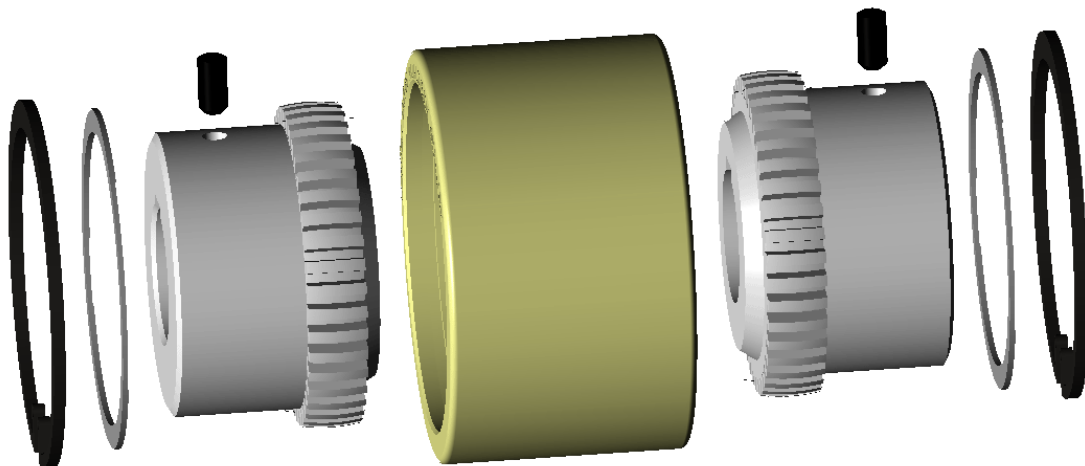

### **5.3 Assembling the DENTEX® coupling**

- Fit the two coupling hubs onto the shafts of the drive and driven side.
- On couplings of the size DT55, DT80 or DT100, fit the two internal retaining rings into the sleeve with a suitable tool.
- Insert the sleeves into the tooth geometry on one of the two sides.
- If you have an assembly drawing, fasten together the two coupling hubs as specified in the drawing. During this process, check dimension E (Figure 1) and if necessary readjust.
- If not, bring the unit together axially until dimension E (Figure 1) has been achieved.

- If the units on the motor and pump side are already attached, dimension E (Figure 1) can be set by moving the coupling hubs axially.
- Secure the hubs by tightening the radial threaded pins DIN EN ISO 4029 with cup point. You can find the tightening torques in Table 4.
- If you are fitting a DENTEX® coupling hub with clamped design, you can find the tightening torque in Table 5.

**Table 4: Tightening torques for threaded pins**

Threaded pin DIN EN ISO 4029 with cup point	M4	M5	M6	M8	M10	M12	M16
Tightening torques $T_A$ [N <sub>m</sub> ]	1.5	2	4	10	17	40	80

**Table 5: Tightening torques for clamping screws**

Cheese head screw with hexagonal socket acc. to DIN 912-12.9	M8	M10	M16	M20	M24
Tightening torques in GGG / ST - $T_A$ [N <sub>m</sub> ]	25	69	295	410	710

## **5.4 Additional assembly of the DENTEX® coupling, type B4R**

- The stop rings and retaining rings must be fitted on both sides.
- One stop ring and one retaining ring each must be slid over the cylindrical end of the respective coupling hub. Once the coupling hub has been successfully fitted into the coupling sleeve, slide the stop ring into the coupling sleeve until it is resting against the toothing.
- Then fit the retaining ring into the slot provided in the coupling sleeve, using a suitable tool.
- This assembly process should be repeated on the other side, in the same sequence.

## **5.5 Additional assembly of the DENTEX® coupling, type B3R**

- In this case, the stop rings and retaining rings must be fitted on one side.
- First fit the internal retaining ring into the slot provided in the coupling sleeve, using a suitable tool.
- Then slide the stop ring and retaining ring over the cylindrical end of the coupling hub. Once the coupling hub has been successfully fitted into the coupling sleeve, slide the stop ring into the coupling sleeve until it is resting against the toothing.
- Then fit the retaining ring into the slot provided in the coupling sleeve, using a suitable tool.

## 5.6 Displacement types and values



In order to guarantee a long service life for the coupling and to avoid hazards during usage in Ex-zones, the shaft ends must be precisely aligned. It is vital to maintain the specified displacement values, see Table 6. Exceeding these values will damage the coupling. The more precisely the coupling is aligned, the longer its service life will be.



When using the coupling in an Ex-zone for explosion group IIC (designation II 2GD c IIC T X), these displacement values must be halved (see Tables 8 and 9).

**Figure 9: Displacement types and values**

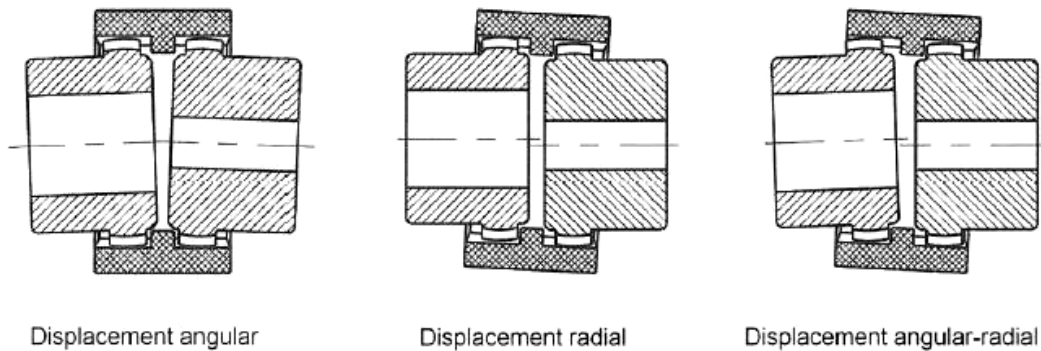

**Table 6: Displacement values**

Type	Rotation n max [1/min]	Torque [Nm]		Output [kW/min-1]		Max. displacement [mm]		
		Normal T <sub>KN</sub>	Max. T <sub>K</sub>	Normal	Max.	axial	radial or angular	
B-14	8000	10	20	0,0010	0,0021	± 1	± 0,3	± 1 per hub
B-19	8000	16	32	0,0017	0,0033		± 0,4	
B-24	8000	20	40	0,0021	0,0042		± 0,6	
B-28	8000	45	90	0,0047	0,0094		± 0,7	
B-32	7000	60	120	0,0063	0,0130		± 0,8	
B-38	6000	80	160	0,0084	0,0170		± 0,4	
B-42	5400	100	200	0,0100	0,0200		± 0,6	
B-48	5000	140	280	0,0150	0,0290		± 0,7	
B-55	4000	250	500	0,0260	0,0520		± 0,8	
B-65	3800	390	780	0,0410	0,0800		± 0,6	
B-80	3000	700	1400	0,0730	0,1500		± 0,7	
B-100	2400	1250	2400	0,1300	25,000		± 0,8	
B3R	24	10200	20	40	0,0020		0,0040	
	28	8300	45	90	0,0045	0,0095	± 0,6	
	32	7000	80	160	0,0084	0,0170	± 0,7	
B3R	45	5000	140	280	0,0150	0,0290	± 0,8	
	65	3800	390	780	0,0410	0,0800	± 0,6	
B4R	80	3000	700	1400	0,0730	0,1500	± 0,7	
	100	2400	1250	2400	0,1300	25,000	± 0,8	

- The displacement values stated in Table 6 are maximum values, which must not occur at the same time. If radial and angular displacement do occur simultaneously, the permissible displacement values may only be used proportionately.
- Use a measuring gauge, ruler or feeler gauge to check whether the permissible displacement values from Table 6 have been maintained.

## **6.0 Spare parts management & addresses:**



Having important spare parts in stock at the installation location is a basic requirement for ensuring the operational readiness of the coupling.



You can find contact addresses of field service staff or partners for spare parts/orders on the R+L HYDRAULICS website at [www.rl-hydraulics.com](http://www.rl-hydraulics.com).

## **7.0 Important information for Ex-zones**

Content still needs checking!

Copyright reserved as per ISO 16016	Signed: 05.10.2010 MBOZ Checked: 01.04.2011 JZIS	Replacement for: Replaced by:
--	---	----------------------------------

R+L HYDRAULICS GmbH Friedrichstr. 6 58791 Werdohl	DENTEX® operating / installation manual	Number: BMA0008 Page: 14 von 14 Version: 1ENG
---	---	---

## **8.0 Additional information:**



The customer bears sole responsibility for all subsequent machining on the coupling components, which are not performed by R+L HYDRAULICS GmbH. All claims for warranty are excluded.



Any subsequent work carried out on coupling components intended for use in Ex-zones, which is not performed by R+L HYDRAULICS, will result in those components becoming immediately unfit for use in Ex-zones. Furthermore, the customer shall bear sole responsibility for any such work. All claims for warranty are excluded.

Copyright reserved as per ISO 16016	Signed: 05.10.2010 MBOZ Checked: 01.04.2011 JZIS	Replacement for: Replaced by:
--	---	----------------------------------