

F2 - 2-bolt flange bearing units

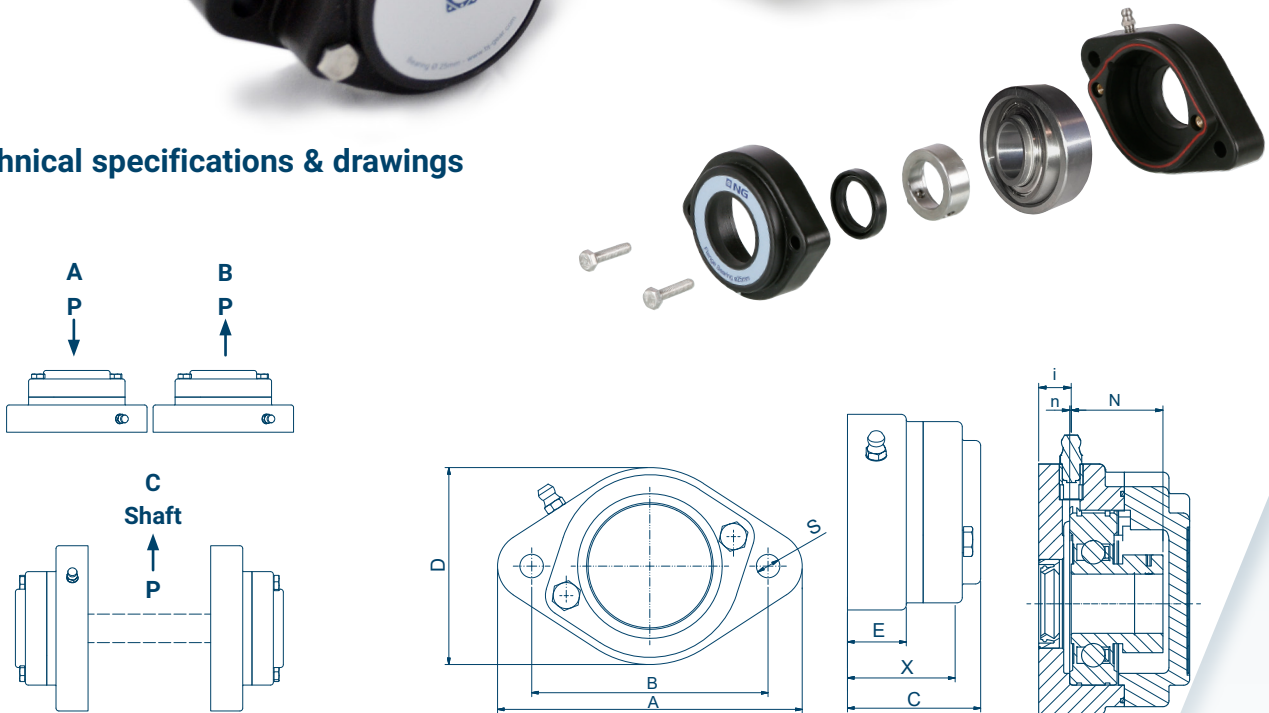

Technical specifications & drawings



Load types for houses

TYPE F2	Item no. closed cover	Item no. open cover	A	B	C	D	E	S	X	i	n	N	Weight [kg]	Max load [kN] (Houses)		
														Type A	Type B	Type C
Ø20 mm	NG20F20	NG20F21	116	90	51	75	22.5	9	43	11	0.5	31.0	0.43	4.58	19.75	29.15
Ø25 mm	NG25F20	NG25F21	123	99	52	79	22.5	9	44	11	0.5	31.5	0.51	4.09	20.11	22.51
Ø30 mm	NG30F20	NG30F21	145	117	58	90	22.5	11	48	11	0.5	36.7	0.77	4.65	11.26	27.24
Ø35 mm	NG35F20	NG35F21	160	130	60	99	22.5	13	50	11	0.5	39.4	0.99	4.98	12.31	27.52
Ø40 mm	NG40F20	NG40F21	174	144	65	110	22.5	13	56	11	0.5	44.7	1.30	3.69	12.80	35.07
Ø50 mm	NG50F20	NG50F21	197	157	70	125	26.5	17.5	58	12	0.5	46.0	1.60	4.58	16.11	44.96
Ø60 mm	NG60F20	NG60F21	250	202	82	152	28.5	22	70	15	0.5	54.8	2.82	4.68	20.43	54.72

All measurements are in millimeters. When ordering please use the catalogue numbers.

BJ-Gear A/S

Niels Bohrs Vej 47
DK-8660 Skanderborg
Denmark

Phone +45 87 40 80 80
Email bj@bj-gear.com
Website www.bj-gear.com