

Rev	Description	Date	Name

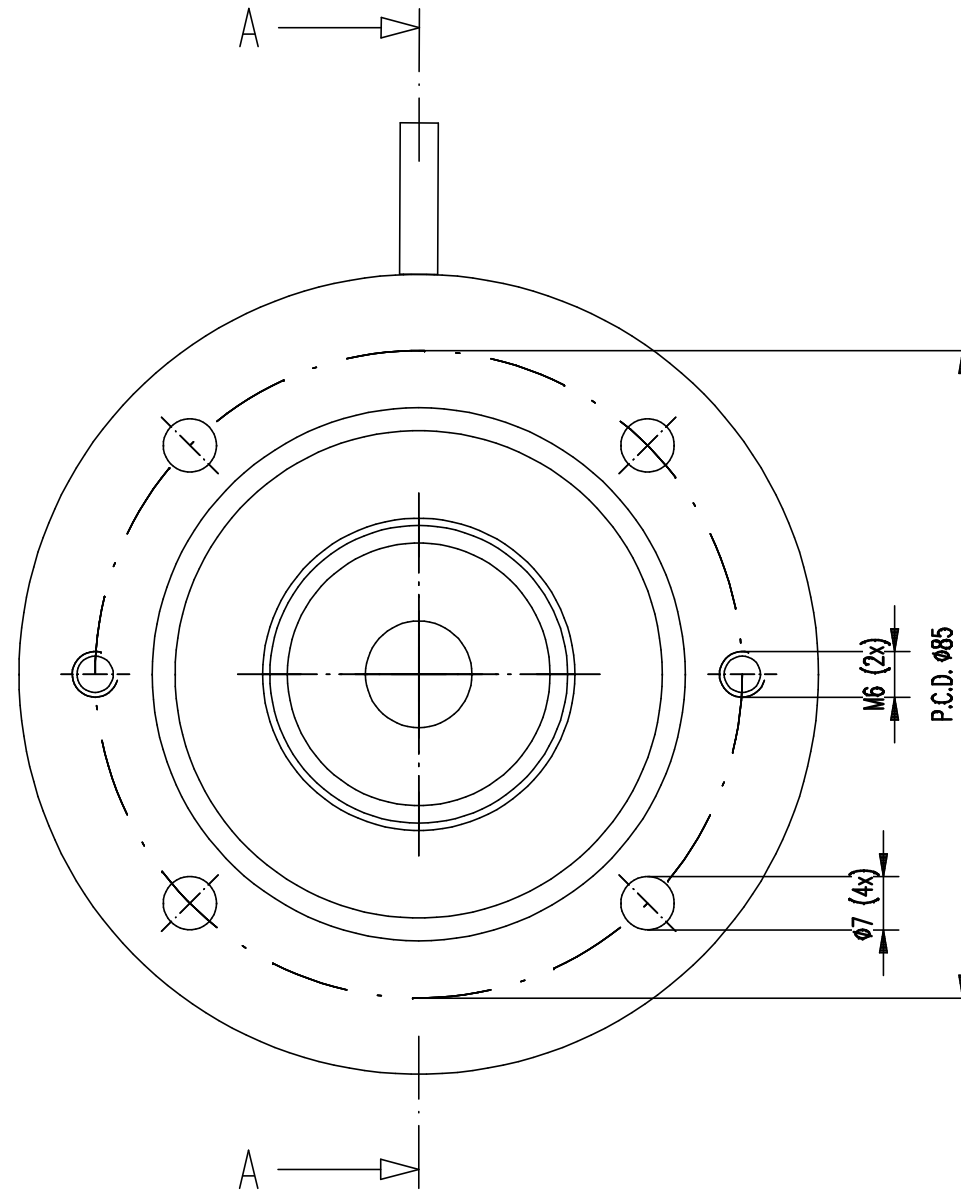
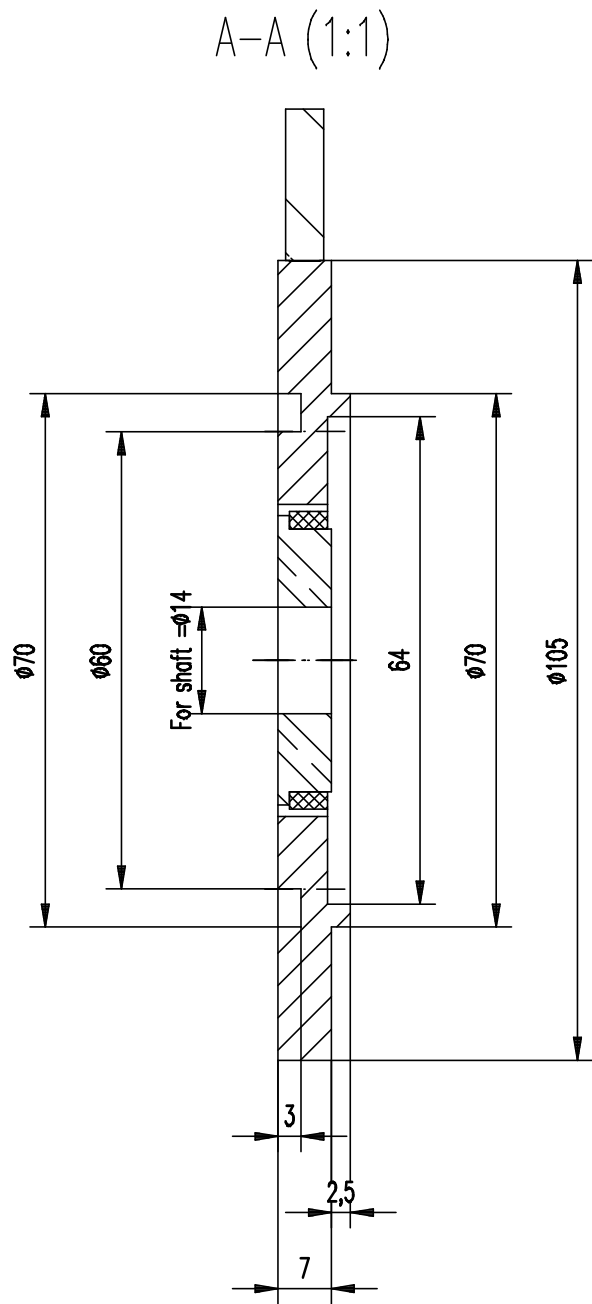
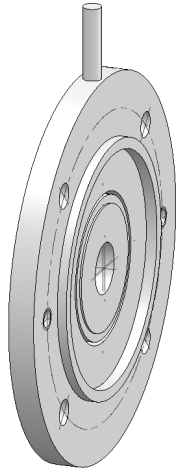

		MODEL. NO.		MATERIAL	WN.	<p>BEGE Aandrijftechniek B.V. BEGE Power Transmission Anton Philipsweg 30 2171 KX Sassenheim Nederland T +31 252-220220 F +31 252-218484 bege@bege.nl www.bege.nl</p>
REV	WEIGHT	DESCRIPTION		DRAWN	CHECKED	
SCALE	DIMENSIONS	MIG Nova+ Flange $\phi 105/7$		13.07.2020	13.07.2020	
1:1	mm	Shaft $\phi 14$		DRW. NO.	DN-0009705	
FORMAT	SH.NO.	ART. NO.	ERP ART. NO.	REF. DRW.	General tolerance DIN-ISO 2768 1-m / 2-K	
A3		AN-0006343			Surface 	

Copyright BEGE, whose property this document remains. No part may be disclosed, duplicated or in any other way made use of except with the written approval of BEGE. All rights reserved.